



REQUEST FOR PROPOSAL (RFP)
FOR
**LEASE OF UNIT FROM CENTRO MINI MALL IN
HULHUMALÉ**

PROPOSAL REFERENCE NUMBER: HDC(161)-CM/IU/2020/234

ANNOUNCEMENT DATE: 05th November 2020

PROPOSAL SUBMISSION DEADLINE: 08th December 2020



properties.hdc.com.mv



TABLE OF CONTENTS

SECTION I. INSTRUCTIONS TO PROPONENTS (ITP).....	2
SECTION II: RFP DATA SHEET.....	15
SECTION III. QUALIFICATION AND EVALUATION CRITERIA.....	17
1. QUALIFICATION CRITERIA.....	17
2. EVALUATION CRITERIA.....	18
SECTION IV. LESSOR'S REQUIREMENTS.....	21
1. SCOPE OF WORKS.....	21
2. LEASE RATE.....	21
3. DRAWINGS.....	21
4. UNIT FRONTAGE AND DESIGN GUIDELINES.....	22
SECTION V. BUSINESS PROPOSAL REQUIREMENT.....	23
1. BID SECURITY AS IN FORM 01.....	23
2. LETTER OF PRICE PROPOSAL AS IN FORM 02.....	23
3. LEGAL DOCUMENTS:.....	23
4. FINANCIAL DOCUMENTS.....	23
5. BUSINESS PLAN:.....	24
6. EXPERIENCE.....	24
7. PROPOSAL CHECKLIST.....	24
SECTION VI. CONTRACT TERMS.....	30

SECTION I. INSTRUCTIONS TO PROPONENTS (ITP)

A. GENERAL		
1. Scope of Proposal	1.1	<p>The Lessor;</p> <p>HOUSING DEVELOPMENT CORPORATION LIMITED an incorporated limited liability company operating under the registration number C793/2008 and having its registered office at HDC Building, 3rd Floor, Hulhumalé Republic of Maldives (hereinafter called and referred to as “the Lessor”.) issues this Request for Proposal (RFP) for Project specified in Section IV. Lessor’s Requirements. The name of the Project and Proposal Reference Number of this RFP is provided in the RFP Data Sheet.</p>
	1.2	<p>Throughout this RFP Documents:</p> <p>(a) the term “in writing” means communicated in written form and delivered against receipt;</p> <p>(b) except where the context requires otherwise, words indicating the singular also include the plural and words indicating the plural also include the singular; and</p> <p>(c) “day” means calendar day.</p>
2. Corrupt and Fraudulent Practices	2.1	<p>It is requirement of Lessor that proponents, suppliers, contractors and their agents (whether declared or not), sub-contractors, sub-consultants, service providers or suppliers, and any personnel thereof, observe the highest standard of ethics during RFP process and execution of Works. In pursuance of this policy, the Lessor:</p> <p>(a) defines, for the purposes of this provision, the terms set forth below as follows:</p> <p>(i) “Corrupt practice” means the offering, giving, receiving, or soliciting of anything of value to influence the action of a public official in the procurement process or in contract execution; and</p>



		<p>(ii) "Fraudulent practice" means a misrepresentation of facts in order to influence a procurement process or the execution of a contract to the detriment of HDC, and includes collusive practice among Proponent (prior to or after Proposal submission) designed to establish Proposal prices at artificial noncompetitive levels and to deprive HDC of the benefits of free and open competition.</p> <p>(b) will reject a proposal for award if it determines that the proponent recommended for award, or any of its personnel, or its agents, or its sub-consultants, sub-contractors, service providers, suppliers and/or their employees, has, directly or indirectly, engaged in corrupt or fraudulent practices in competing for the contract in question.</p> <p>(c) will sanction a firm or individual, at any time including declaring such firm or individual ineligible, either indefinitely or for a stated period of time: to be awarded a contract from Lessor.</p> <p>(d) will terminate the contract after having given fourteen (14) days' notice to the Proponent.</p>
<p>3. Eligible Proponents</p>	<p>3.1</p>	<p>A Proponent must be a registered business (sole trader, partnership or limited liability company) – subject to ITP 3.2 and ITP 3.3.</p>
	<p>3.2</p>	<p>Unless otherwise specified in the RFP data sheet, in case a Joint Venture (JV) is proposed by Proponent(s) the minimum percentage of equity share proportion of local partner(s) in a JV shall not apply.</p>
	<p>3.3</p>	<p>A Proponent shall not have a conflict of interest. Any Proponent found to have a conflict of interest shall be disqualified. A Proponent may be considered to have a conflict of interest for the purpose of this RFP process, if the Proponent:</p> <p>(a) directly or indirectly controls, is controlled by or is under common control with another Proponent; or</p>



		<p>(b) receives or has received any direct or indirect subsidy from another Proponent; or</p> <p>(c) has a relationship with another Proponent, directly or through common third parties, that puts it in a position to influence the proposal of another Proponent, or influence the decisions of the Lessor regarding this RFP process; or</p> <p>(d) submits more than one proposal in this RFP process by business entity. Participation by a Proponent in more than one Proposal will result in the disqualification of all Proposal in which such Proponent is involved.</p>
	3.4	A Proponent shall not be under suspension from proposal submission by the Lessor.
	3.5	A Proponent shall provide such evidence of eligibility satisfactory to the Lessor, as the Lessor shall reasonably request.

B. CONTENTS OF RFP DOCUMENTS

4. Sections of RFP Documents	4.1	<p>The RFP Documents include all the Sections specified below, and should be read in conjunction with any Addenda issued in accordance with ITP 6.</p> <ul style="list-style-type: none"> • Section I. Instructions to Proponents (ITP) • Section II. RFP Data Sheet • Section III. Qualification and Evaluation Criteria • Section IV. Lessor's Requirements • Section V. Business Proposal Requirement • Section VI. Terms of Contract
	4.2	Unless obtained directly from the Lessor, the Lessor is not responsible for the completeness of the RFP Documents, responses to requests for clarification, or Addenda to the RFP Documents in accordance with ITP 6. In case of any contradiction, documents obtained directly by the Lessor shall prevail.
	4.3	The Proponent is expected to examine all instructions, forms, terms, and specifications in the RFP Documents. Failure to furnish all information and documentation

		required in RFP Documents as per ITP 4.1 may result in rejection of the proposal.
5. Clarification of RFP Documents, Pre-Proposal Meeting	5.1	A Proponent requiring any clarification of the RFP Documents shall contact the Lessor in writing at the Lessor's address specified in the RFP Data Sheet or raise its enquiries during the Pre-Proposal Meeting, if provided for in accordance with ITP 5.2. The Lessor will respond in writing to any request for clarification, provided that such request is received no later than the enquiry deadline specified in the RFP Data Sheet . The Lessor shall promptly publish its response at the web page specified in the RFP Data Sheet . Should the clarification result in changes to the essential elements of the RFP Documents, the Lessor shall amend the RFP Documents following the procedure under ITP 6 and ITP 16.2.
	5.2	If so, specified in the RFP Data Sheet , the Proponent's designated representative is invited to attend a pre-proposal meeting. The purpose of the meeting will be to provide information about the project, proposal procedures, clarify issues and to answer questions on any matter that may be raised at that stage.
	5.3	Minutes of the pre-bid meeting, if applicable, including the text of the questions asked by Proponents, without identifying the source, and the responses given, together with any responses prepared after the meeting, will be published promptly in webpage in accordance to ITP 5.1. Any modification to the RFP Documents that may become necessary as a result of the pre-proposal meeting shall be made by the Lessor exclusively through the issue of an Addendum pursuant to ITP 6 and not through the minutes of the pre-proposal meeting. Nonattendance at the pre-proposal meeting will not be a cause for disqualification of a Bidder.
6. Amendment of RFP Documents	6.1	At any time prior to the deadline for submission of proposal, the Lessor may amend the RFP Documents by issuing addenda.

	6.2	Any addendum issued shall be part of the RFP Documents and shall promptly publish the addendum on the Lessor's web page in accordance with ITP 5.1.
	6.3	To give Proponents reasonable time in which to take an addendum into account in preparing their proposal, the Lessor should extend the deadline for the submission of proposal, pursuant to ITP 16.2.
C. PREPARATIONS OF PROPOSALS		
7. Cost of Proposal	7.1	The Proponent shall bear all costs associated with the preparation and submission of its proposal, and the Lessor shall not be responsible or liable for those costs, regardless of the conduct or outcome of the RFP Process.
8. Language of Proposal	8.1	The RFP, as well as all correspondence and documents relating to the RFP exchanged by the Proponent and the Lessor, shall be written in the ENGLISH or DHIVEHI language.
9. Documents Comprising the Proposal	9.1	<p>The Proposal shall comprise the following:</p> <ul style="list-style-type: none"> (a) Letter of Price Proposal Form in accordance with ITP 10; (b) Bid Security in accordance with ITP 13; (c) Written confirmation authorizing the signatory of the Proposal to commit the Proponent, in accordance with ITP 14.2 and ITP 14.3; (d) Business Proposal Requirement stipulated in Section V; (e) In the case of a Proposal submitted by a Joint Venture (JV), the JV agreement or letter of intent to enter into JV including but not limited to scope of works to be executed by respective partners and equity share percentage of the respective partners; (f) Any other document required in RFP data sheet.

10. Letter of Price Proposal	10.1	The Letter of Price Proposal shall be prepared using the Form 02 in Section V. The form must be completed without any alterations to the text, and no substitutes shall be accepted. All blank spaces shall be filled in with the information requested.
	10.2	The Proponent shall quote prices conforming to the requirements specified in Section IV.
11. Currencies of Proposal	11.1	The currency(ies) of the proposal are to be quoted in Maldivian Rufiyaa (MVR).
12. Period of Validity of Proposals	12.1	Proposal shall remain valid for the period specified in the RFP Data Sheet . A proposal valid for a shorter period shall be rejected by the Lessor as non-responsive.
13. Bid Security	13.1	The Proponent shall furnish as part of its proposal, a bid security in original form and in the amount and currency specified in the RFP Data Sheet .
	13.2	The Bid Security shall be valid for the period specified in the RFP Data Sheet .
	13.3	The Bid Security shall be a demand guarantee in forms of an unconditional guarantee issued by a locally registered Bank or financial institution (such as an insurance, bonding or surety company). The bid security shall be submitted as per Form 01 in Section V.
	13.4	The Bid Security of a JV shall be in the name of the JV that submits the bid. If the JV has not been legally constituted into a legally enforceable JV at the time of bidding, the bid security or shall be in the names of all future members as named in the letter of intent referred to in ITP 3.1 and ITP 9.1
	13.5	Any proposal not accompanied by a substantially responsive bid security shall be rejected by the Lessor as non-responsive.
	13.6	The Bid Security of the successful Proponent shall be returned as promptly as possible once the successful Proponent has signed the Contract.

	13.7	The Bid Security of unsuccessful Proponents shall be returned as promptly as possible upon the successful Proponent's signing the Contract.
14. Format and Signing of Proposal	14.1	The Proponent shall submit one original of the documents comprising the proposal as described in ITP 9.1.
	14.2	The original and all copies of the proposal shall be typed or written in indelible ink and shall be signed by a person duly authorized to sign on behalf of the Proponent. This authorization shall consist of a written confirmation of a Power of Attorney to sign on behalf of the Proponent. The name and position held by each person signing the authorization must be typed or printed below the signature. All pages of the proposal where entries or amendments have been made shall be signed or initialed by the person signing the proposal.
	14.3	In case the Proponent is a JV, the Proposal shall be signed by an authorized representative of the JV on behalf of the JV, and so as to be legally binding on all the members as evidenced by a power of attorney signed by their legally authorized representatives.
	14.4	Any inter-lineation, erasures, or overwriting shall be valid only if they are signed or initialed by the person signing the proposal.
15. Sealing and Marking of Proposals	15.1	Proponents shall submit their proposal by mail or by hand. If so, specified in the RFP Data Sheet , Proponents shall have the option of submitting their Proposal electronically. Procedures for submission, sealing and marking are as follows: (a) Proponents submitting Proposal by mail or by hand shall enclose the original of the Bid in one sealed single envelope, duly marking the envelope as "ORIGINAL BID". (b) Proponent submitting Proposal electronically shall follow the electronic bid submission procedures specified in the RFP data sheet .
	15.2	The inner and outer envelopes shall:

		<p>(a) bear the name and address of the Proponent;</p> <p>(b) bear the name of the Project and shall be addressed to the Lessor;</p> <p>(c) bear the specific proposal reference number of this RFP process indicated in RFP Data Sheet;</p> <p>(d) bear the name, address and contact number and contact person of the Proponent.</p> <p>(e) bear a warning not to open before the time and date for proposal opening in accordance with ITP 16.1.</p> <p>(f) include Form 04 - Proposal Checklist</p>
	15.3	If all envelopes are not sealed and marked as required, the Lessor will assume no responsibility for the misplacement or premature opening of the proposal.
16. Deadline for Submission of Proposal	16.1	Proposals must be received by the Lessor at the address and no later than the Proposal Submission date and time specified in the RFP Data Sheet.
	16.2	The Lessor may, at its discretion, extend the deadline for the submission of proposals by amending the RFP Documents in accordance with ITP 6, in which case all rights and obligations of the Lessor and Proponents previously subject to the deadline shall thereafter be subject to the deadline as extended.
17. Late Proposal	17.1	The Lessor shall not consider any proposals that arrives after the deadline for submission of proposal specified in ITP 16. Any proposal received by the Lessor after the deadline for submission of proposal shall be declared late, rejected, and returned unopened to the Proponent.
18. Proposal Opening	18.1	The Lessor shall open Proposals at the address on the date and time specified in the RFP Data Sheet in the presence of Proponent's designated representatives and anyone who choose to attend. Any specific electronic bid opening procedures required if electronic bidding is permitted in accordance with ITP 15.1, shall be specified in the RFP Data Sheet.

	18.2	<p>The Lessor shall open the proposals one at a time and read out and record the following</p> <p>(a) the name of the Proponent;</p> <p>(b) the presence of original Bid Security;</p> <p>(c) the proposed prices in Price Proposal Form;</p> <p>(d) any other details as the Lessor may consider appropriate</p>
	18.3	<p>Only proposals read out and recorded at proposal opening shall be considered for evaluation. No Proposal shall be rejected at the opening except for late proposal in accordance with ITP 17.1 and proposals that are not in accordance with Form 04 - Proposal Checklist.</p>
	18.4	<p>The Lessor shall prepare a record of the proposal opening that shall include, as a minimum: the name of the Proponent; the Price; and the presence or absence of a bid security, if one was required. The Proponents' representatives who are present shall be requested to sign the record. The omission of a Proponent's signature on the record shall not invalidate the contents and effect of the record. A copy of the record shall be distributed to all Proponents who submitted proposal on time.</p>

D. EVALUATION AND COMPARISON OF PROPOSALS

19. Confidentiality	19.1	<p>Information relating to the evaluation of proposals, comparison of proposals and recommendation of contract award shall not be disclosed to Proponents or any other persons not officially concerned with the RFP process until information on Contract award is communicated to all Proponents in accordance with ITP 27.</p>
	19.2	<p>Any attempt by a Proponent to influence the Lessor in the evaluation of the proposals or Contract award decisions may result in the rejection of its proposal.</p>
	19.3	<p>Notwithstanding ITP 20.2, from the time of proposal opening to the time of Contract award, if a Proponent</p>



		wishes to contact the Lessor on any matter related to the RFP process, it shall do so in writing.
20. Clarification of Proposals	20.1	To assist in the examination, evaluation, and comparison of the proposals, and qualification of the Proponents, the Lessor may, at its discretion, ask any Proponent for a clarification of its proposal, giving a reasonable time for a response. Any clarification submitted by a Proponent that is not in response to a request by the Lessor shall not be considered. The Lessor's request for clarification and the response shall be in writing. No change, including any voluntary increase or decrease, in the prices or substance of the proposal shall be sought, offered, or permitted, except to confirm the correction of arithmetic errors discovered by the Lessor in the evaluation of the proposals, in accordance with ITP 24.
	20.2	If a Proponent does not provide clarifications of its proposal by the date and time set in the Lessor's request for clarification, its proposal may be rejected.
21. Deviations, Reservations, and Omissions	21.1	<p>During the evaluation of proposal, the following definitions apply:</p> <ul style="list-style-type: none"> (a) "Deviation" is a departure from the requirements specified in the RFP Documents; (b) "Reservation" is the setting of limiting conditions or withholding from complete acceptance of the requirements specified in the RFP Documents; and (c) "Omission" is the failure to submit part or all of the information or documentation required in the RFP Documents.
22. Determination of Responsiveness	22.1	The Lessor's determination of a proposal's responsiveness is to be based on the contents of the proposal itself, as defined in ITP 9.1.
	22.2	A substantially responsive proposal is one that meets the requirements of the RFP Documents without material deviation, reservation, or omission.
	22.3	A substantially responsive proposal is one that meets the requirements of the RFP Documents without material



		<p>deviation, reservation, or omission. A material deviation, reservation, or omission is one that,</p> <p>(a) if accepted, would</p> <p>(i) affect in any substantial way the scope, quality, or performance of the Works specified in the Contract; or</p> <p>(ii) limit in any substantial way, inconsistent with the RFP Documents, the Lessor's rights or the Proponent's obligations under the proposed Contract; or</p> <p>(b) if rectified, would unfairly affect the competitive position of other Proponents presenting substantially responsive proposal.</p>
<p>23. Correction of Arithmetical Errors</p>	<p>22.4</p>	<p>If a proposal is not substantially responsive to the requirements of the RFP Documents, it shall be rejected by the Lessor and may not subsequently be made responsive by correction of the material deviation, reservation, or omission.</p>
	<p>23.1</p>	<p>Provided that the proposal is substantially responsive, the Lessor shall correct arithmetical errors on the following basis:</p> <p>(a) if there is a discrepancy between the unit price and the total price that is obtained by multiplying the unit price and quantity, the unit price shall prevail and the total price shall be corrected, unless in the opinion of the Lessor there is an obvious misplacement of the decimal point in the unit price, in which case the total price as quoted shall govern and the unit price shall be corrected;</p> <p>(b) if there is an error in a total corresponding to the addition or subtraction of subtotals, the subtotals shall prevail and the total shall be corrected; and</p> <p>(c) if there is a discrepancy between words and figures, the amount in words shall prevail, unless the amount expressed in words is related to an arithmetic error, in which case the</p>



		amount in figures shall prevail subject to (a) and (b) above.
	23.2	Proponents shall be requested to accept correction of arithmetical errors. Failure to accept the correction in accordance with ITP 23.1, shall result in the rejection of the Proposal.
24. Evaluation of Proposal	24.1	The Lessor shall use the criteria and methodologies listed in Section III Qualification and Evaluation Criteria.
25. Lessor's Right to Accept Any Proposal, and to Reject Any or All Proposal	25.1	The Lessor reserves the right to accept or reject any proposal, and to annul the RFP process and reject all proposal at any time prior to contract award, without thereby incurring any liability to Proponents. In case of annulment, all proposals submitted and specifically, bid securities, shall be promptly returned to the Proponents.
E. AWARD OF CONTRACT		
26. Award Criteria	26.1	Subject to ITP 25.1, the Lessor shall conditionally award the Contract to the Proponent(s) whose proposals has been determined to be substantially responsive to the RFP Documents and scored the highest marks as specified in ITP 24.1, provided further that the Proponent is determined to be qualified to perform the Contract satisfactorily.
	26.2	In case multiple lease units specified in Section IV, the Lessor shall conditionally award the Contract to the Proponents as per evaluation ranking subject to ITP 26.1
27. Unit Selection	27.1	Priority for unit selection shall be given to the successful Proponent based on evaluation ranking.
28. Notification of Conditional Award	28.1	Prior to the expiration of the period of proposal validity, the Lessor shall notify the successful Proponent, in writing, that its proposal has been accepted.
	28.2	Until a formal contract is prepared and executed, the successful Proponents' proposal and the notification of conditional award shall constitute a binding Contract.

	28.3	Failure of the successful Proponent to fulfill the obligations in ITP 29 and ITP 30 or sign the Contract in accordance with ITP 31 shall constitute sufficient grounds for the annulment of the conditional award and forfeiture of the bid security. In that event the Lessor may award the Contract to the next highest evaluated Proponent whose offer is substantially responsive and is determined by.
29. Concept Drawing & Work Schedule	29.1	Within 20 (twenty) days of the receipt of notification of conditional award from the Lessor, the successful Proponent shall submit concept design and work schedule.
	29.2	In case the Proponent is required to submit the concept drawing in Section V. Business Proposal Requirement, the Lessor will review the submitted concept drawing and if required provide comments for concept drawing along with the notification of conditional award. The successful proponent shall rectify the concept drawing and submit revised concept drawing within 14 (fourteen) days of the receipt of notification of conditional award from the Lessor.
30. Lease Deposit	30.1	Within 07 (Seven) days of notification and prior to execution of the signing of agreement in accordance with ITP 30.1, the successful proponent shall pay a lease deposit, equivalent to three (03) months rent for the year one (01), to the account which will be notified in the Letter of Award. Promptly upon notification, the Lessor shall send the successful Proponent the Contract Agreement.
31. Signing of Contract	31.1	Promptly upon notification of the conditional award, the Lessor shall send the successful Proponent the Contract.
	31.2	Within 7 (seven) days of the success fulfilment of the obligation stipulated in ITP 29 and ITP 30, successful Proponent shall sign the Contract with Lessor.

SECTION II: RFP DATA SHEET

A. GENERAL	
ITP 1.1	Name of the Project: Lease of Unit – 8 From Centro Mini Mall in Hulhumalé.
ITP 1.1	The Reference Number of Proposal Process is: HDC(161)-CM/IU/2020/234
ITP 3.2	Joint Venture share proportion restriction shall not apply.
B. CONTENTS OF RFP DOCUMENTS	
ITP 5.1	For clarification purposes only, the Lessor's address is: Business Development, Marketing & Sales Housing Development Corporation Ltd. Ground Floor, HDC Building Hulhumalé, Maldives Tel: (+960)3355 369, (+960)3355 293 E-mail: sales@hdc.com.mv
ITP 5.1	Webpage: Corporate website - hdc.com.mv MyHulhumalé Properties website - properties.hdc.com.mv
ITP 5.1	The deadline for request for clarification is on or before 19th November 2020 at 1400 hrs
ITP 5.2	The pre-proposal meeting shall take place at the following date, time and place; Date: 16th November 2020 Time: 1400hrs Place: Online Meeting held via Zoom Link for online Zoom meeting will be shared to the registered parties for pre-proposal meeting. In order to minimize technical issues please join the meeting 10 minutes prior to the time.
C. PREPARATIONS OF PROPOSALS	
ITP 12.1	Proposal Validity Period: 150 (One Hundred and Fifty) days
ITP 13.1	The Amount and Currency of Bid Security shall be MVR 5,000.00 (Maldivian Rufiyaa Five Thousand) or equivalent in United States Dollar (USD) .



	The source of exchange rate shall be Maldives Monetary Authority (MMA) and the date for the exchange rate shall be 14 (fourteen) days before Proposal Submission deadline.
ITP 13.2	Bid Security Validity Period: 180 (One Hundred and Eighty) days from the deadline for submission of Proposals.
D. SUBMISSION AND OPENING OF PROPOSALS	
ITP 15.1	Proponents do not have the option of submitting their proposal electronically.
ITP 16.1	<p>For proposal submission purpose only, the Lessor Address is:</p> <p>Exhibition Center (Ground Floor) HDC Building Huvandhumaa Hingun Housing Development Corporation Ltd.</p> <p>Date: 08th December 2020 Time: 1300hrs to 1400hrs</p>
ITP 18.1	<p>For proposal opening shall take place at:</p> <p>Exhibition Center (Ground Floor) HDC Building Huvandhumaa Hingun Housing Development Corporation Ltd.</p> <p>Date: 08th December 2020 Time: 1415hrs</p> <p><i>Proponents do not have the option of submitting their proposal electronically.</i></p>



SECTION III. QUALIFICATION AND EVALUATION CRITERIA

This Section contains all the criteria that the Lessor shall use to qualify Proponents and evaluate the proposals. In accordance with ITP 24, no other factors, methods or criteria shall be used. The Proponent shall provide all the information requested in the Section V, Business Proposal Requirements and proposal shall fulfill requirements in accordance with ITP 9.1.

1. QUALIFICATION CRITERIA

Proponents that meets the requirement set in Qualification Criteria of Section III will be evaluated according to evaluation criteria.

1.1 Financial Resources

- (a) Proponent shall demonstrate that it has access to or has full funds to finance the proposed investment cost. Proponents who that do not demonstrate it access to or has full funds to meet the proposed investment cost shall be disqualified.
- (b) Funds required for the investment cost will be evaluated based on the bank statement balance, cash and cash equivalents, receivables, payables and inventory (if relevant) from audited financial statements or external financing subjected to Proponents proposed method of financing.

1.2 Outstanding Payment

- (a) Proponent shall not have any outstanding payment due to Lessor. Proponents who have payment due at the date of submission RFP shall be disqualified.

1.3 History of Non-Performing Contracts and Litigation History

- (a) Proponents shall not have consistent history of court/arbitral award decisions against the Lessor for the last five (5) years.
- (b) Proponent shall not have occurrence of non-performance of a contract awarded by Lessor as a result of Proponent default for the last five (5) years

2. EVALUATION CRITERIA

Proposals that meets the requirement set in Qualification Criteria of Section III will be evaluated based on the following criteria and points will allocated as below:

Criteria	Allocated %
a) Lease Rate	75%
b) Business Plan	15%
c) Experience	10%
Total	100%

2.1 LEASE RATE – 75%

- 2.1.1 The lease rate will be evaluated using the Net Present Value of the proposed lease rate by the Proponent for the first 5 (Five) years after grace period.
- 2.1.2 NPV will be calculated as per the following formula with the discount rate of 10%
- 2.1.3 Proponents with the highest acceptable NPV will be given a score of 100 points for the lease rate, whereby points shall be given as prorated for the other Proponents.

$$\sum_{0}^{n} \frac{I}{(1+r)^n}$$

n= number of years

I = rent proposed per month for each year starting from first year

r= discount rate (10%)

- 2.1.4 Lease rate shall be proposed as per Section IV Lessors' Requirement and proposals that are not in accordance Section IV shall result in disqualification of proposal.
- 2.1.5 Procedure to Eliminate Outliers
- a) In evaluation of lease rate, procedure to eliminate the outliers as per below shall be applied.
- Lower Quartile (LQ) - 25% percentile
 - Upper Quartile (UQ) - 75% percentile
 - Interquartile Range (IQR) = UQ - LQ
 - **Lower Boundary = Minimum Acceptable Net Present Value (NPV)**
 - **Upper Boundary = UQ + (IQR x 0.5)**
- b) If the Net Present Value (NPV) of the proposed lease rate is higher than the Upper Boundary, the proposal shall be disqualified.

Sample for Eliminating Outliers

The below is a sample of how outlier rates are eliminated.

Minimum Acceptable NPV per Square feet 470.65

Step 1: Comparison of NPV of acceptable proposals

Proponent Name	NPV	
Proponent 1	797.37	Accepted
Proponent 2	713.73	Accepted
Proponent 3	817.56	Accepted
Proponent 4	761.38	Accepted
Proponent 5	896.05	Rejected
Proponent 6	982.46	Rejected
Proponent 7	796.03	Accepted
Proponent 8	711.86	Accepted
Proponent 9	759.32	Accepted
Proponent 10	852.89	Accepted

Step 2: Calculating Quartile Range

Lower Quartile	759.84
Upper Quartile	844.06
Interquartile Range	84.22

Step 3: Calculating Acceptable Range

Lower Boundary	470.65
Upper Boundary	886.17

Note:

- Lower Quartile (LQ) - 25% percentile
- Upper Quartile (UQ) - 75% percentile
- Interquartile Range (IQR) = UQ – LQ
- **Lower Boundary = Minimum Acceptable Net Present Value (NPV)**
- **Upper Boundary = UQ + (IQR x 0.5)**

2.2 BUSINESS PLAN – 15%

The business plan will be evaluated based on the following criterion:

- 2.2.1 Marketing Analysis and Strategy - 40 points
- 2.2.2 Financial Plan - 30 points
- 2.2.3 Management and Operational Plan - 30 points

2.3 EXPERIENCE 10%

- 2.3.1 Experience will be evaluated based on the number of years in similar operation. Highest score for operation experience will be given for registered establishments that have been in operation in a relevant field for the past 5 (five) years and score will be given pro-rata basis for Proponents with less than 5 (five) years operation experience.
- 2.3.2 Scale of current operations will be considered based on revenue. Highest score for scale of operation shall be given to the Proponents with highest average revenue of the past 3 years and score will be given pro-rata basis for other Proponents.

SECTION IV. LESSOR'S REQUIREMENTS

1. SCOPE OF WORKS

Housing Development Corporation (Lessor) is seeking for interest parties for Development and Operation of Retail store in Hulhumalé Centro Mini Mall Unit 8. The selected party (Lessee) will be responsible for the design, develop and operation of the unit for the duration of the lease term.

2. LEASE RATE

- 2.1 The minimum acceptable lease rate per square feet per month for Centro Unit 8 is MVR 30.00 (Maldivian Rufiyaa Thirty) for the first 5 (Five) years.
- 2.2 Proponent is eligible to a discount rate in Year 1 and Year 2.
 - 20% discount is applicable for proposed lease rate of Year 1.
 - 10% discount is applicable for proposed lease rate of Year 2.
 - Lease rate for Year 3, Year 4 and Year 5 discount shall not apply.
- 2.3 The lease rate proposed for each following year shall be equal or higher than the previous year's rental rate. Proposed lease rate which is less than the said minimum acceptable lease rate shall be disqualified.

3. DRAWINGS

The drawing contains the location map and unit map of the unit to be allocated for the project. (Refer to next page)

Unit Number	Usage	Plot Area
Unit - 8	Retail Store	306.66 sqft.

** Areas in the drawings is subjected to minimal changes.*



LOCATION MAP (LOT 11131)

PHASE 1

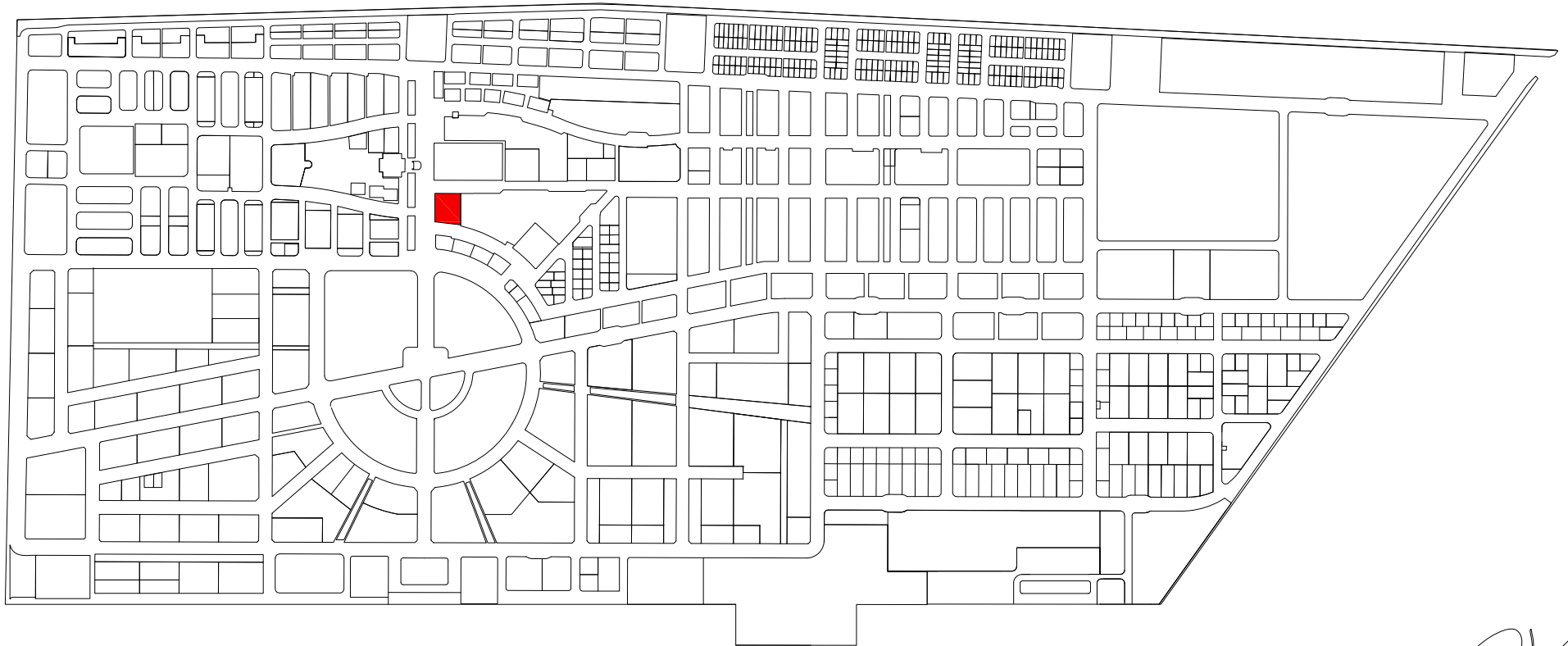

LOT 11131 (CENTRO MALL)

PLOT AREA: 1834.89 SQM / 19750.54 SQFT
SCALE: NTS

PROJECT : CENTRO MALL (LOT 11131)

DRAWING : LOCATION MAP

HOUSING DEVELOPMENT CORPORATION
PLANNING DEPARTMENT
3RD FLOOR, HDC BUILDING HULHUMALE'
REPUBLIC OF MALDIVES
TEL. +9603353535, FAX +9603358892
EMAIL : mail@hdc.com.mv

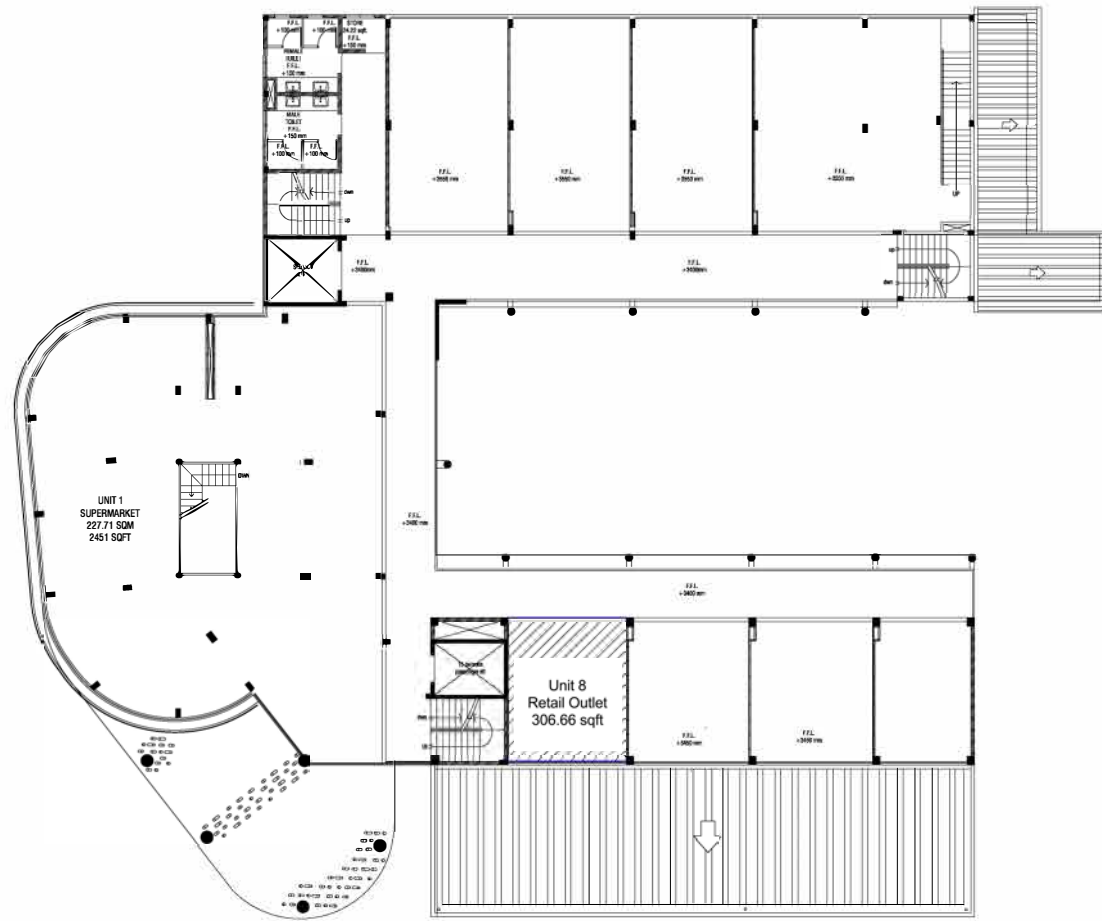

LOT 11131 (CENTRO MALL) - SECOND FLOOR

PLOT AREA: 1834.89 SQM / 19750.54 SQFT
 BUILDING AREA: 1029.32 SQM / 11079.50 SQFT
 UNIT 8 AREA: 28.49 SQM / 306.66 SQFT
 SCALE: 1:300



PROJECT : CENTRO MALL (LOT 11131)

Scale : AS GIVEN Drawn by: Anson Checked by: Saif Date: 14th September 2020 Remarks:

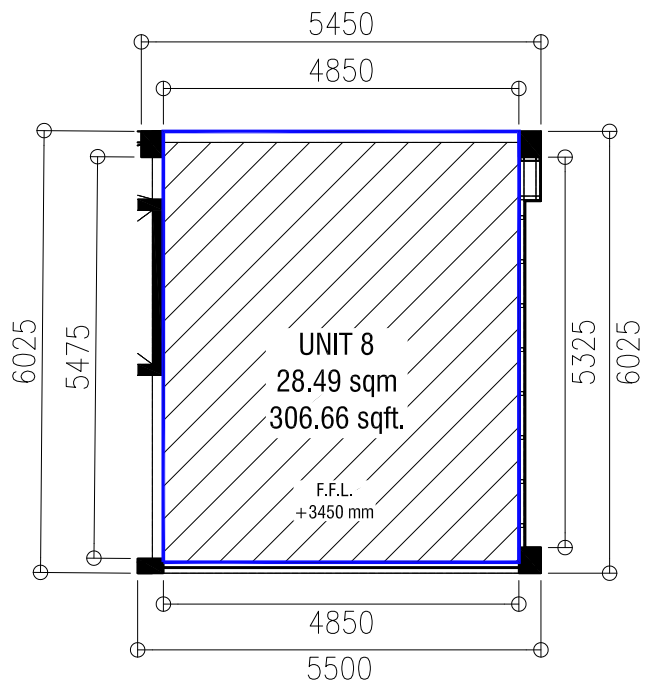

CENTRO MALL - SECOND FLOOR PLAN
 UNIT 8: AREA: 28.49 SQM / 306.66 SQFT

SCALE: 1:100

PROJECT : CENTRO MALL (LOT 11131)

Scale : AS GIVEN Drawn by: Ansen Checked by: Saif Date: 14th September 2020 Remarks:

HOUSING DEVELOPMENT CORPORATION
 PLANNING DEPARTMENT
 3RD FLOOR, HDC BUILDING HULHUMALE'
 REPUBLIC OF MALDIVES
 TEL. +9603353535, FAX +9603358892
 EMAIL : mail@hdc.com.mv

4. UNIT FRONTAGE AND DESIGN GUIDELINES

(Refer to Next Page)





PLANNING & DEVELOPMENT DEPARTMENT

CENTRO
COMERCIAL UNITS
UNIT FRONTAGE & DESIGN GUIDELINES
05/11/2020

1. INTRODUCTION

This document is intended to communicate the standards and guidelines to be followed by tenants occupying units from Centro Mini-mall.

2. GENERAL GUIDELINES

- Frontage refers to the front side, towards the corridor where entrance to the unit is located.
- This guideline is applicable to all commercial units in Centro.
- Drawings should be submitted to HDC for approval. (Refer to the drawing requirements)
- Any onsite works should be carried after HDC approves the design drawings.

3. FAÇADE

- The predominant material for façade needs to be glass. This is to ensure liveliness of the commercial front and surrounding.
- The front door glass can be covered up to 40% of total façade by a sticker/frosting/opaque material according to branding preferences.
- A roller shutter door can be used to close at the end of business hours.
- Minimum height of the entrance door should be 2.1m.
- All units must have disability access of provided within the units.
- The name board should be fixed on top or side of the unit at the space allocated. (*refer to guideline drawings)
- If a tenant needs to install a security camera, a dome type camera is allowed to be placed on the façade.
- All AC outdoor units should be fixed at a location identified by HDC. The location of the outdoor unit shall be proposed by HDC at the services design stage of each unit. This should then be approved by HDC.
- Access to services (if any), need to be provided when finishing.

4. DRAWING REQUIREMENT

Drawings should be submitted to HDC for approval. Below are the minimum requirements required for approval.

- Detailed Floor Plans with dimensions
- Exterior & interior elevations
- Services drawings fit to guidelines set by relevant authorities and approved by them. - Fire drawings approved by MNDF.
- Structural drawings, if any such changes are proposed (should be signed by a Certified Structural Engineer)
- Electrical load calculations need to be submitted for commercial units that uses high voltage such as (but not limited to) supermarkets, cafe's, restaurants etc.
- The load calculations submitted, signed by a registered professional from the relevant authorities.

5. OTHERS

- The tenant should be responsible for any damages incurred to the property and/or its users in installing / modifying any component of the unit.
- Drilling of beams or any structural element is prohibited.

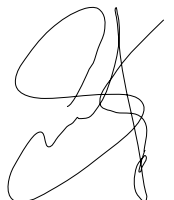

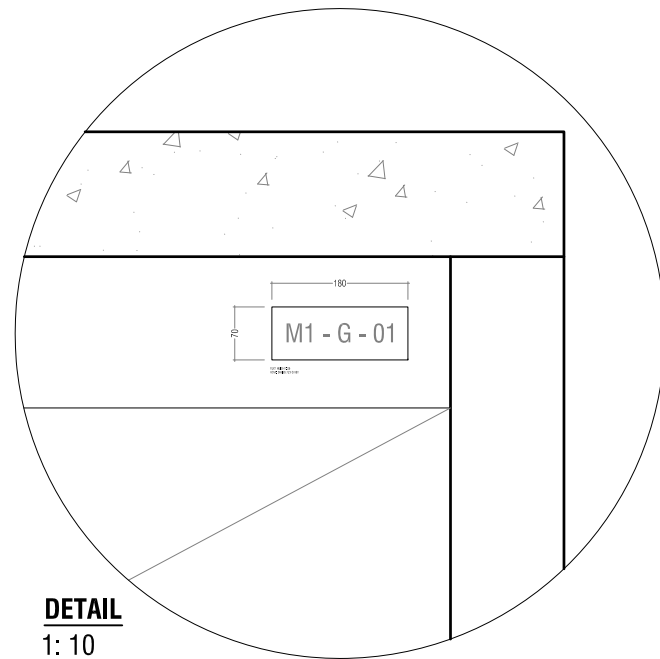
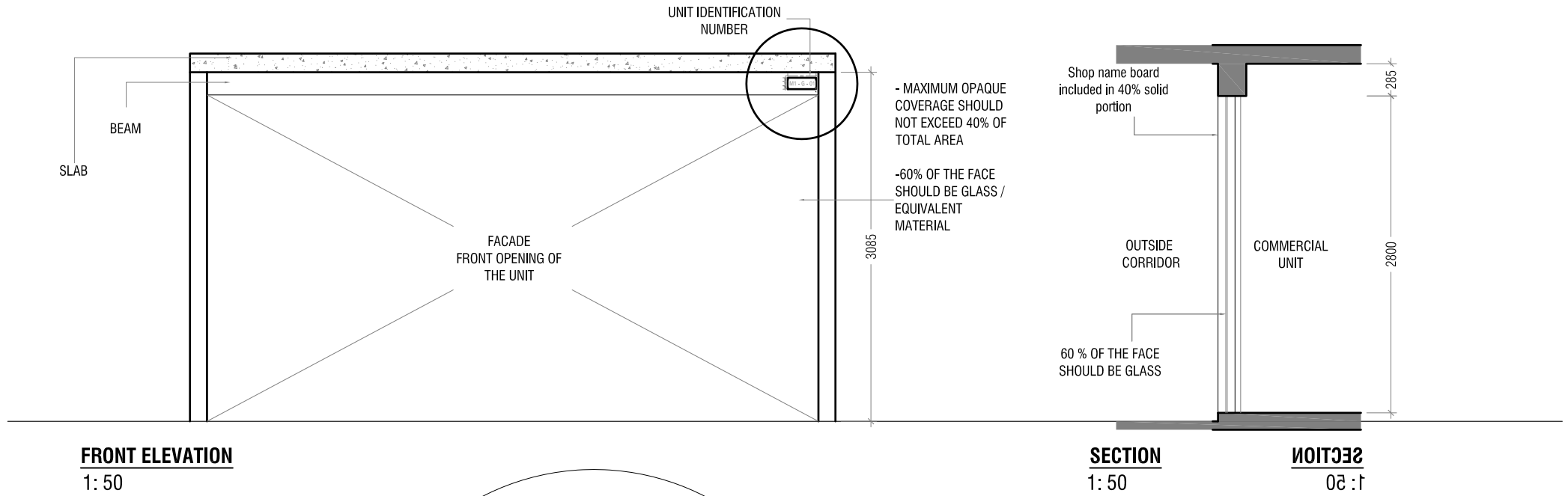

TEXT HEIGHT: 25
FONT: SWISS 721 Cn BT

70

180

M1 - G - 01



TEXT HEIGHT: 25
FONT: SWISS 721 Cn BT

SECTION V. BUSINESS PROPOSAL REQUIREMENT

To establish its qualifications to perform the contract in accordance with *Section III Qualification and Evaluation Criteria* and to determine the proposal as substantially responsive proposal, Proponent shall provide the information requested in the corresponding documents included hereunder.

1. BID SECURITY AS IN FORM 01

2. LETTER OF PRICE PROPOSAL AS IN FORM 02

3. LEGAL DOCUMENTS:

- 3.1 Copy of Business Registration Certificate.
- 3.2 Copy of GST Registration certificate (for the relevant and similar work)
- 3.3 Copy of Trade permit (for the relevant and similar work).
- 3.4 For Partnership: Partnership Deed / Agreement
- 3.5 For Company; Memorandum and Articles of Association of the Company.
- 3.6 For Company; Board Resolution of the Company confirming Board of Director's approval for proposed work.
- 3.7 Information of the Authorized Representative as in Form 03.
- 3.8 Power of Attorney to sign on behalf of the Proponent in accordance with ITP 14.2.
- 3.9 In the case of a Proposal submitted by a Joint Venture (JV), the JV agreement or letter of intent to enter into JV including but not limited to scope of works to be executed by respective partners and equity share percentage of the respective partners;

4. FINANCIAL DOCUMENTS

- 4.1 Financial proposal including method of financing the proposed investment and estimated investment value. Proposed method of financing for investment can be equity financing, equity injection, bank finance, external finance such as financier company, lines of credit, time deposit, tradable bonds or combination of various financing methods.
- 4.2 Copy of GST and BPT Returns Statement of the past 3 (three) years.
- 4.3 For Sole Proprietorship, bank statements of the most recent 06 (six) months of the business entity or the monthly balance or monthly average balance confirmation. The submitted statement shall be original, authorized and sealed by the bank / financial institution.
- 4.4 For Company, audited financial statements of the past three 03 (three) years authorized by a certified audit firm / individual and management account of the current year.



- 4.5 If Bank financing is proposed by Proponents, bank comfort letter, bank guarantee or any other relevant documents shall be submitted. The submitted documents shall include the Proponent(s) name and name of proposed work/project.
- 4.6 If equity injection or external financing is proposed by Proponents, relevant documents including but not limited to Proponent(s) name, name of the proposed work/project and letter of commitment for financier shall be submitted demonstrating access to or availability of funds.

5. BUSINESS PLAN:

The Proponent shall submit a business plan including:

- 5.1 Marketing Analysis and Strategy
 - a) Market analysis including target market and competitors.
 - b) Marketing strategy including product strategy, price strategy and promotional strategy.
- 5.2 Financial Plan
 - a) Financial forecast
 - b) Investment appraisal and indicators
- 5.3 Management and Operational Plan
 - a) Proposed project schedule
 - b) Management and operational details
 - c) Resource requirement and Human resources plan.

6. EXPERIENCE

- 6.1 Proponent shall submit documents proving their experience including project completion letters including project values, reference letter or any other relevant documents proving the experience in the field or similar business activities.

7. PROPOSAL CHECKLIST

- 7.1 Proposal Checklist as in Form 04 should be attached outside the sealed envelope.

FORM 01: BID SECURITY FORM

WHEREAS, (*name of Proponent*) (hereinafter called "the Proponent") has submitted their bid dated (*date of submission of bid*) to (name of works) in (*insert lot number*), Hulhumalé (hereinafter called "the Bid").

KNOW ALL PEOPLE by these presents that We (*name of bank*) having our registered office at (*address of bank*) (hereinafter called "the Bank") are bound unto the Housing Development Corporation Ltd of the Republic of Maldives, registration number C-793/2008 (hereinafter called "Lessor") in the sum of MVR (*Maldivian Rufiyaa*) for which payment well and truly to be made to the said Lessor, the Bank binds itself, its successors, and assigns by these presents.

SEALED with the Common Seal of the said Bank this Day of 2020.

THE CONDITIONS of this obligation are:

1. If the Proponent

(a) Withdraws its Bid during the period of bid validity

2. If the Proponent, having been notified of the acceptance of its Bid by the Housing Development Corporation Ltd during the period of bid validity:

(a) Refuses to accept the award;

(b) Fails or refuses to pay Lease Deposit; or

(c) Fails to execute the term and conditions of Lease Agreement; or

We undertake to pay to the Lessor up to the above amount upon receipt of his first written demand, without the Lessor having to substantiate his demand, provided that in his demand the Lessor will note that the amount claimed by him is due to him owing to the occurrence of the above condition.

This Guarantee will remain in force up to and including the date (insert date) 180 days from (*date of proposal submission*) after the deadline for submission of this Guarantee or as it may be extended by the Lessor, notice of which extension(s) shall be given to the Bank. Any demand in respect of this Guarantee shall reach the Bank not later than the above date.

This guarantee shall supersede all agreements between us and the Proponent in relation to this Bid. If there are any inconsistencies between this guarantee and any other document exchanged between us and the Proponent, the terms of this guarantee shall prevail.

This guarantee shall be governed by and construed in accordance with the laws of Republic of Maldives.

(Seal and signature of the bank / financial institution)



FORM 02: LETTER OF PRICE PROPOSAL

Date:
Name of the Project:
Proposal Reference No:
Unit No:

To: Housing Development Corporation Ltd.
Ground Floor, HDC Building
Hulhumalé, Maldives

We, the undersigned, declare that:

- (a) We have examined and have no reservations to the Request for Proposal (RFP) documents including all addenda issued in accordance with Instruction to Proponents (ITP) 6.
- (b) We meet the eligibility requirements and have no conflict of interest in accordance with ITP 3.3;
- (c) We have not been suspended nor declared ineligible by the Lessor in accordance with ITP 3.4.
- (d) We have no litigation history and non-performance of a contract in accordance with Section III.
- (e) We, (insert *business name and business registry number*), offer to (insert name of the Project) in Unit (*Insert Unit number*).
- (f) We undertake, to pay the proposed rent for 05 (five) years, where proposal is accepted. The proposed lease rent of our proposal is:

1st Year (per square feet per month): MVRL (*amount in numbers*)
(RufiyaaLaari.....) (*amount in words*)

2nd Year (per square feet per month): MVR L (*amount in numbers*)
(RufiyaaLaari.....) (*amount in words*)

3rd Year (per square feet per month): MVR L (*amount in numbers*)
(RufiyaaLaari.....) (*amount in words*)

4th Year (per square feet per month): MVR L (*amount in numbers*)
(RufiyaaLaari.....) (*amount in words*)

5th Year (per square feet per month): MVR L (*amount in numbers*)
(RufiyaaLaari.....) (*amount in words*)



- (g) Our proposal shall be valid for a period of One Hundred and Eighty (180) days from the date of proposal submission deadline in accordance with RFP document and it shall remain binding upon us and may be accepted at any time before the expiration of that period.
- (h) We understand that this proposal, together with your written acceptance thereof included in your notification of award, shall constitute a binding contract between us, until a formal contract is prepared and executed; and
- (i) We understand that Lessor is not bound to accept the highest evaluated proposal or any proposal that may receive.

Proponent:

Name:

(Seal)

Address:

Duly authorized to sign the proposal for and on behalf of the Company:

Name:

Title:

Signature:

Date:



FORM 03: INFORMATION OF THE AUTHORIZED REPRESENTATIVE

Date:

Proposal Reference No:.....

To: Housing Development Corporation Ltd.
Ground Floor, HDC Building
Hulhumalé, Maldives

This is to authorize (*Name, ID number*) as a representative of (*Name of the Proponent*) to carry out the Project related to RFP (ref no) and to liaise with Lessor on behalf of the (*Name of the Proponent*)

Proponent:

Name:

Address:

.....

Signature and Stamp

Authorized Representative (preferably fulltime personal):

Name:

Designation:

ID Number:

Contact Number:

Email Address:

.....

Signature



FORM 04 - PROPOSAL CHECKLIST

Proponents are required to Form 04 – Proposal Checklist outside the sealed envelope of the Proposal

Proponent	For HDC use	
<input type="checkbox"/>	<input type="checkbox"/>	1. Bid Security as in FORM 01
<input type="checkbox"/>	<input type="checkbox"/>	2. Letter of Price Proposal as in FORM 02
<input type="checkbox"/>	<input type="checkbox"/>	3. Copy of Business Registration Certificate
<input type="checkbox"/>	<input type="checkbox"/>	4. Board Resolution as in SECTION V 3.6
<input type="checkbox"/>	<input type="checkbox"/>	5. Proposal Checklist ss in FORM 04 attached outside sealed proposal.

NOTE:

- PROPOSALS WITHOUT THE SPECIFIED DOCUMENTS STATED IN THE FORM 04 PROPOSAL CHECKLIST WILL BE REJECTED AT THE TIME OF PROPOSAL OPENING.

SECTION VI. CONTRACT TERMS

1.	Parties to the Agreement	<p>Housing Development Corporation Ltd HDC Building Hulhumalé</p> <p>(hereinafter referred to as "lessor", which expression shall include its successors-in-title, liquidators, administrators and lawful assignees where the context so requires or admits).</p> <p>[Address of the successful Proponent]</p> <p>(hereinafter referred to as "lessee", which expression shall include its successors-in-title, liquidators, administrators and lawful assignees where the context so requires or admits)</p>
2.	Objective	2.1. The objective of this agreement is to lease the unit specified in Clause 5 to develop and operate for retail purpose.
3.	Concept Drawings & Work Schedule	5.1 Submission of concept drawings and work schedule within 20 (twenty) calendar days from the receipt of conditional award letter
4.	Unit Detail	7.1. The unit to be leased is Centro Mini Mall Unit Number 8 measuring an area of 306.66 square feet.
5.	Unit Usage	8.1. The unit should only be used to operate a retail store.
6.	Lease Term	9.1. The lease period is 5 years from the date of signing the agreement.
7.	Lease Rate	<p>10.1 The lease rate per month for five years will be the proposed lease rate of the successful Proponent.</p> <p>10.2 Discount of 20% for the first year and 10 % for the second year shall be applied on proposed lease rate.</p> <p>10.3 The lease rate will be effective from the date of unit handover.</p>
8.	Grace Period	11.1. The first 3 (Three) months of the Term shall be a grace period where no rent shall be payable by the lessee.
9.	Lease Deposit	<p>13.1 The lease deposit amount shall be 03 (three) months' lease of the proposed lease rate of the successful Proponent.</p> <p>13.2 This amount should be paid within 7 (seven) working days from the date of conditional award.</p>

<p>10.</p>	<p>Duties and Obligations of Lessee</p>	<p>18.1 Utilize the leased Premises only for the specific commercial usage, and remain consistent in carrying out the work.</p> <p>18.2 Use the Premises to provide facilities or services that conform to the rules and regulations and Lessor's guidelines which may be issued and/or modified from time to time, and the rules and regulations enforced by the relevant Authority or any other institution in charge of issuing of permits or authorizations.</p> <p>18.3 Make payments to the relevant Authorities for all utility services consumed or supplied inclusive of electricity meters, water meters and telecommunication connections to the Premises during the Term. The Lessor and the Lessee confirm the readings for the electricity and water supply meters on the Premises at the time of occupation of the Premises.</p> <p>18.4 Not to assign, sublet, charge or part with or share possession or otherwise dispose of the Premises or any of its rights, obligations, or responsibilities under the Agreement without the prior written consent of the Lessor.</p>
<p>11.</p>	<p>Option to Renew Term</p>	<p>18.5 The Lessor may at its discretion give the Lessee option to renew or extend the Term, provided that the Lessee requests to renew or extend the Term at least 6 (Six) months prior to expiration of the Term. However, such renewal or extension may be granted based on the Lessee's performance under the Agreement. The Lessor and the Lessee shall negotiate the new extension of the Term. In the event that the Lessor and the Lessee fail to reach mutual agreement with regard to the terms and conditions for renewal or extension of the Term latest by 3 (Three) months prior to expiration of the Term, then the Agreement shall expire at the end of the Term.</p>
<p>12.</p>	<p>Termination</p>	<p>19.1 Lessor may serve 30 (thirty) calendar days written notice to the lessee to terminate the agreement in the event the lessee fails to pay the rent and/or penalty as per the terms of the agreement for a period of 3 (three) consecutive months</p> <p>19.2 The lessor may terminate the agreement without any compensation payable to the lessee in the event the rent due and/or penalty remains unpaid as the end of 30 (thirty) calendar days written notice period</p> <p>19.3 If the lessee fails to perform any of its obligation under the agreement, the lessee shall be granted a period to rectify the breach along with a fine amount between MVR 5,000 and MVR 100,000 considering the degree of the breach, to be determined by the sole discretion of the lessor.</p>

		<p>19.4 If the lessee fails to pay the fine and cure the breach within the extension period, the lessor has the right to terminate the agreement and give the lessee a duration of not less than 30 (thirty) calendar days to vacate the unit and handover the unit to the lessor</p> <p>19.5 The lessee may terminate the agreement immediately without any prior written notice, if the lessee fails to perform any of the fundamental obligations</p> <p>19.6 The lessee may terminate the agreement by serving 6 (six) months' written notice upon the lessor of its intention to do so for any reason whatsoever.</p>
--	--	--

DISCLAIMER:

- **This contract terms only includes the key points of the agreement. The agreement is not limited to the clauses included in this contract terms.**
- **The proposal submitted by the successful Proponent shall be a part of the agreement.**

