

# REQUEST FOR PROPOSAL (RFP)

FOR

**DEVELOPMENT AND OPERATION OF CHANNEL PARK CAFÉ /  
RESTAURANTS IN HULHUMALE'**

**PROPOSAL REFERENCE NUMBER:** HDC(161)-MKS/IU/2022/385

**ANNOUNCEMENT DATE:** 08<sup>th</sup> September 2022

**PROPOSAL SUBMISSION DEADLINE:** 02<sup>nd</sup> October 2022

**TABLE OF CONTENTS**

SECTION I. INSTRUCTIONS TO PROPONENTS (ITP) ..... 2

SECTION II. RFP DATA SHEET..... 14

SECTION III. LESSOR'S REQUIREMENTS..... 17

    1. SCOPE OF WORK ..... 17

    2. BUSINESS MODEL ..... 17

    3. ESTIMATED PROJECT COST BY LESSOR..... 17

    4. PLOT DETAILS ..... 18

SECTION IV. QUALIFICATION AND EVALUATION CRITERIA ..... 19

    1. QUALIFICATION CRITERIA..... 19

    2. EVALUATION CRITERIA..... 20

SECTION V. BUSINESS PROPOSAL REQUIREMENT ..... 24

    1. BID SECURITY AS IN FORM 01 ..... 24

    2. LETTER OF PROPOSAL AS IN FORM 02 ..... 24

    3. LEGAL DOCUMENTS:..... 24

    4. FINANCIAL DOCUMENTS..... 24

    5. EXPERIENCE..... 26

    6. BUSINESS PLAN ..... 26

    7. PROPOSAL CHECKLIST ..... 27

SECTION VI. CONTRACT TERMS..... 40

SECTION VII. DRAWINGS AND GUIDELINES ..... 47

    1. DRAWINGS..... 47

    2. DESIGN AND DEVELOPMENT GUIDELINE ..... 48

    3. SUBMISSION & QUALITY MANAGEMENT CRITERIA ..... 49



*Handwritten signature or initials in blue ink.*

**SECTION I. INSTRUCTIONS TO PROPONENTS (ITP)**

<b>A. GENERAL</b>		
<b>1. Scope of Proposal</b>	1.1	<p>The Lessor;</p> <p>HOUSING DEVELOPMENT CORPORATION LIMITED an incorporated limited liability company operating under the registration number C793/2008 and having its registered office at HDC Building, 3rd Floor, Hulhumalé Republic of Maldives (hereinafter called and referred to as "the Lessor"), issues this Request for Proposal (RFP). The name of the Project and Proposal Reference Number of this RFP is <b>provided in the RFP Data Sheet.</b></p>
	1.2	<p>Throughout this RFP Documents:</p> <p>(a) the term "in writing" means communicated in written form and delivered against receipt;</p> <p>(b) except where the context requires otherwise, words indicating the singular also include the plural and words indicating the plural also include the singular; and</p> <p>(c) "day" means calendar day.</p>
<b>2. Corrupt and Fraudulent Practices</b>	2.1	<p>It is a requirement of the Lessor that proponents, developers, contractors and their agents (whether declared or not), sub-contractors, sub-consultants, service providers or suppliers, and any personnel thereof, observe the highest standard of ethics during RFP process and execution of Works. In pursuance of this policy, the Lessor:</p> <p>(a) defines, for the purposes of this provision, the terms set forth below as follows:</p> <p>(i) "Corrupt practice" means the offering, giving, receiving, or soliciting of anything of value to influence the action of a public official in the procurement process or in contract execution; and</p> <p>(ii) "Fraudulent practice" means a misrepresentation of facts in order to influence a procurement process or the execution of a contract to the detriment of HDC, and includes collusive practice among Proponent (prior to or after Proposal submission) designed to establish Proposal prices at artificial noncompetitive levels and to deprive HDC of the benefits of free and open competition.</p>

		<p>(b) will reject a proposal for award if it determines that the proponent recommended for award, or any of its personnel, or its agents, or its sub-consultants, sub-contractors, service providers, suppliers and/or their employees, has, directly or indirectly, engaged in corrupt or fraudulent practices in competing for the contract in question.</p> <p>(c) will sanction a firm or individual, at any time including declaring such firm or individual ineligible, either indefinitely or for a stated period of time: to be awarded a contract from Lessor.</p> <p>(d) will terminate the contract after having given fourteen (14) days' notice to the Proponent.</p>
<p><b>3. Eligible Proponents</b></p>	<p>3.1</p>	<p>A Proponent must be a registered business (sole trader, partnership or limited liability company) – subject to ITP 3.2 and ITP 3.3.</p>
	<p>3.2</p>	<p><b>Unless otherwise specified in the RFP data sheet,</b> in case a Joint Venture (JV) is proposed by Proponent(s) the minimum percentage of equity share proportion of local partner(s) in a JV shall not apply.</p>
	<p>3.3</p>	<p>A Proponent shall not have a conflict of interest. Any Proponent found to have a conflict of interest shall be disqualified. A Proponent may be considered to have a conflict of interest for the purpose of this RFP process, if the Proponent:</p> <p>(a) directly or indirectly controls, is controlled by or is under common control with another Proponent; or</p> <p>(b) receives or has received any direct or indirect subsidy from another Proponent; or</p> <p>(c) has a relationship with another Proponent, directly or through common third parties, that puts it in a position to influence the proposal of another Proponent, or influence the decisions of the Lessor regarding this RFP process; or</p> <p>(d) submits more than one proposal for the plots in this RFP process by business entity. Participation by a Proponent in more than one Proposal will result in the disqualification of all Proposals in which such</p>

		Proponent is involved.
	3.4	A Proponent shall not be under suspension from proposal submission by the Lessor.
	3.5	A Proponent shall provide such evidence of eligibility satisfactory to the Lessor, as the Lessor shall reasonably request.
	3.6	If a proponent has a relation with an employee within HDC, that is in a position to influence the proposal of the proponent, or influence the decisions of the Lessor regarding the RFP process, the proponent shall declare the relationship as per the Declaration Form in Section V.  In a case where the Proponent has not declared, Lessor has the right to disqualify the submitted proposal.
<b>B. CONTENTS OF RFP DOCUMENTS</b>		
<b>4. Sections of RFP Documents</b>	4.1	The RFP Documents include all the Sections specified below, and should be read in conjunction with any Addenda issued in accordance with ITP 6. <ul style="list-style-type: none"> <li>• Section I. Instructions to Proponents (ITP)</li> <li>• Section II. RFP Data Sheet</li> <li>• Section III. Lessor's Requirements</li> <li>• Section IV. Qualification and Evaluation Criteria</li> <li>• Section V. Business Proposal Requirement</li> <li>• Section VI. Contract Terms</li> <li>• Section VII. Drawings and Guidelines</li> </ul>
	4.2	Unless obtained directly from the Lessor, the Lessor is not responsible for the completeness of the RFP Documents, responses to requests for clarification, or Addenda to the RFP Documents in accordance with ITP 6. In case of any contradiction, documents obtained directly by the Lessor shall prevail.
	4.3	The Proponent is expected to examine all instructions, forms, terms, and specifications in the RFP Documents. Failure to furnish all information and documentation required in RFP Documents as per ITP 4.1 may result in rejection of the proposal.
<b>5. Clarification of</b>	5.1	A Proponent requiring any clarification of the RFP

<b>RFP Documents, Pre-Proposal Meeting</b>		<p>Documents shall contact the Lessor in writing at the Lessor's address <b>specified in the RFP Data Sheet</b> or raise its enquiries during the Pre-Proposal Meeting, if provided for in accordance with ITP 5.2. The Lessor will respond in writing to any request for clarification, provided that such request is received no later than the enquiry deadline <b>specified in the RFP Data Sheet</b>. The Lessor shall promptly publish its response at the web page <b>specified in the RFP Data Sheet</b>. Should the clarification result in changes to the essential elements of the RFP Documents, the Lessor shall amend the RFP Documents following the procedure under ITP 6 and ITP 16.2.</p>
	5.2	<p>If so, <b>specified in the RFP Data Sheet</b>, the Proponent's designated representative is invited to attend a pre-proposal meeting. The purpose of the meeting will be to provide information about the project, proposal procedures, clarify issues and to answer questions on any matter that may be raised at that stage.</p>
	5.3	<p>Minutes of the pre-proposal meeting, if applicable, including the text of the questions asked by Proponents, without identifying the source, and the responses given, together with any responses prepared after the meeting, will be published promptly in webpage in accordance to ITP 5.1. Any modification to the RFP Documents that may become necessary as a result of the pre-proposal meeting shall be made by the Lessor exclusively through the issue of an Addendum pursuant to ITP 6 and not through the minutes of the pre-proposal meeting. Nonattendance at the pre-proposal meeting will not be a cause for disqualification of a Bidder.</p>
<b>6. Amendment of RFP Documents</b>	6.1	<p>At any time prior to the deadline for submission of proposal, the Lessor may amend the RFP Documents by issuing addenda.</p>
	6.2	<p>Any addendum issued shall be part of the RFP Documents and shall promptly publish the addendum on the Lessor's web page in accordance with ITP 5.1.</p>
	6.3	<p>To give Proponents reasonable time in which to take an addendum into account in preparing their proposal, the Lessor may extend the deadline for the submission of proposal, pursuant to ITP 16.2.</p>

<b>C. PREPARATIONS OF PROPOSALS</b>		
<b>7. Cost of Proposal</b>	7.1	The Proponent shall bear all costs associated with the preparation and submission of its proposal, and the Lessor shall not be responsible or liable for those costs, regardless of the conduct or outcome of the RFP Process.
<b>8. Language of Proposal</b>	8.1	The RFP, as well as all correspondence and documents relating to the RFP exchanged by the Proponent and the Lessor, shall be written in the ENGLISH or DHIVEHI language.
<b>9. Documents Comprising the Proposal</b>	9.1	<p>The Proposal shall comprise the following:</p> <ul style="list-style-type: none"> <li>(a) Bid Security in accordance with ITP 13;</li> <li>(b) Written confirmation authorizing the signatory of the Proposal to commit the Proponent, in accordance with ITP 14.2 and ITP 14.3;</li> <li>(c) Business Proposal Requirement stipulated in Section V;</li> <li>(d) In the case of a Proposal submitted by a Joint Venture (JV), the JV agreement or letter of intent to enter into JV including but not limited to scope of works to be executed by respective partners and equity share percentage of the respective partners;</li> <li>(e) Any other document required in RFP data sheet.</li> </ul>
<b>10. Letter of Proposal</b>	10.1	The Letter of Proposal shall be prepared using the Form 02 in Section V. The form must be completed without any alterations to the text, and no substitutes shall be accepted. All blank spaces shall be filled in with the information requested.
	10.2	The Proponent shall quote prices conforming to the requirements specified in Section III.
<b>11. Currencies of Proposal</b>	11.1	The currency(ies) of the proposal are to be quoted in Maldivian Rufiyaa (MVR).
<b>12. Period of Validity of Proposals</b>	12.1	Proposal shall remain valid for the period <b>specified in the RFP Data Sheet</b> . A proposal valid for a shorter period shall be rejected by the Lessor as non-responsive.

<b>13. Bid Security</b>	13.1	The Proponent shall furnish as part of its proposal, a bid security in original form and in the amount and currency <b>specified in the RFP Data Sheet.</b>
	13.2	The Bid Security shall be valid for the period <b>specified in the RFP Data Sheet.</b>
	13.3	The Bid Security shall be a demand guarantee in forms of an unconditional guarantee issued by a locally registered Bank or financial institution (such as an insurance, bonding or surety company). The bid security shall be submitted as per Form 01 in Section V.
	13.4	The Bid Security of a JV shall be in the name of the JV that submits the bid. If the JV has not been legally constituted into a legally enforceable JV at the time of bidding, the bid security shall be in the names of all future members as named in the letter of intent referred to in ITP 3.1 and ITP 9.1
	13.5	Any proposal not accompanied by a substantially responsive bid security shall be rejected by the Lessor as non-responsive.
	13.6	The Bid Security of the successful Proponent shall be returned as promptly as possible once the successful Proponent has signed the Contract.
	13.7	The Bid Security of unsuccessful Proponents shall be returned as promptly as possible upon the successful Proponent's signing the Contract.
	13.8	The Bid Security may be forfeited or the Bid Securing Declaration Executed:  (a) If the proponent withdraws its Proposal during the period of Proposal validity specified by the Proponent in the Letter of Proposal; or  (b) If the successful proponent (i) fails or refuses to pay lease deposit, or (ii) fails to execute the terms and conditions of the conditional award of the Lessor.
<b>14. Format and Signing of Proposal</b>	14.1	The Proponent shall submit one original of the documents comprising the proposal as described in ITP 9.1.
	14.2	The original and all copies of the proposal shall be typed or



		written in indelible ink and shall be signed by a person duly authorized to sign on behalf of the Proponent. This authorization shall consist of a written confirmation of a Power of Attorney to sign on behalf of the Proponent. The name and position held by each person signing the authorization must be typed or printed below the signature. All pages of the proposal where entries or amendments have been made shall be signed or initialed by the person signing the proposal.
	14.3	In case the Proponent is a JV, the Proposal shall be signed by an authorized representative of the JV on behalf of the JV, and so as to be legally binding on all the members as evidenced by a power of attorney signed by their legally authorized representatives.
	14.4	Any inter-lineation, erasures, or overwriting shall be valid only if they are signed or initialed by the person signing the proposal.

**D. SUBMISSION AND OPENING OF PROPOSALS**

<b>15. Sealing and Marking of Proposals</b>	15.1	<p>Proponents shall submit their proposal by mail or by hand. If so, <b>specified in the RFP Data Sheet</b>, Proponents shall have the option of submitting their Proposal electronically. Procedures for submission, sealing and marking are as follows:</p> <p>(a) Proponents submitting Proposal by mail or by hand shall enclose the original of the Bid in one sealed single envelope, duly marking the envelope as "ORIGINAL BID".</p> <p>(b) Proponent submitting Proposal electronically shall follow the electronic bid submission procedures <b>specified in the RFP data sheet</b>.</p>
	15.2	<p>The sealed envelope shall:</p> <p>(a) bear the name and address of the Proponent;</p> <p>(b) bear the name of the Project and shall be addressed to the Lessor;</p> <p>(c) bear the specific proposal reference number of this RFP process indicated in RFP Data Sheet;</p> <p>(d) bear the name, address and contact number and contact person of the Proponent.</p> <p>(e) bear a warning not to open before the time and date</p>



		for proposal opening in accordance with ITP 16.1. (f) include Form 07 - Proposal Checklist
	15.3	If the envelope is not sealed and marked as required, the Lessor will assume no responsibility for the misplacement or premature opening of the proposal.
<b>16. Deadline for Submission of Proposal</b>	16.1	Proponents must submit the required documents to the online portal no later than the date and time <b>specified in the RFP Data Sheet.</b>
	16.2	Proposals must be received by the Lessor at the address and no later than the Proposal Submission date and time <b>specified in the RFP Data Sheet.</b>
<b>17. Late Proposal</b>	17.1	The Lessor shall not consider any proposals that arrives after the deadline for submission of proposal specified in ITP 16. Any proposal received by the Lessor after the deadline for submission of proposal shall be declared late, rejected, and returned unopened to the Proponent.
<b>18. Proposal Opening</b>	18.1	The Lessor shall open Proposals at the address on the date and time <b>specified in the RFP Data Sheet</b> in the presence of Proponent's designated representatives and anyone who choose to attend. Any specific electronic bid opening procedures required if electronic bidding is permitted in accordance with ITP 15.1, shall be <b>specified in the RFP Data Sheet.</b>
	18.2	The Lessor shall open the proposals one at a time and read out and record the following  (a) the name of the Proponent;  (b) the presence of original Bid Security;  (c) any other details as the Lessor may consider appropriate.
	18.3	Only proposals read out and recorded at proposal opening shall be considered for evaluation. No Proposal shall be rejected at the opening except for late proposal in accordance with ITP 17.1 and proposals that are not in accordance with Form 07 - Proposal Checklist.
	18.4	The Lessor shall prepare a record of the proposal opening that shall include, as a minimum: the name of the Proponent; the Price; and the presence or absence of a bid

		security, if one was required. The Proponents' representatives who are present shall be requested to sign the record. The omission of a Proponent's signature on the record shall not invalidate the contents and effect of the record. A copy of the record shall be distributed to all Proponents who submitted proposal on time.
<b>E. EVALUATION AND COMPARISON OF PROPOSALS</b>		
<b>19. Confidentiality</b>	19.1	Information relating to the evaluation of proposals, comparison of proposals and recommendation of contract award shall not be disclosed to Proponents or any other persons not officially concerned with the RFP process until information on Contract award is communicated to all Proponents in accordance with ITP 28.
	19.2	Any attempt by a Proponent to influence the Lessor in the evaluation of the proposals or Contract award decisions may result in the rejection of its proposal.
	19.3	Notwithstanding ITP 20.2, from the time of proposal opening to the time of Contract award, if a Proponent wishes to contact the Lessor on any matter related to the RFP process, it shall do so in writing.
<b>20. Clarification of Proposals</b>	20.1	To assist in the examination, evaluation, and comparison of the proposals, and qualification of the Proponents, the Lessor may, at its discretion, ask any Proponent for a clarification of its proposal, giving a reasonable time for a response. Any clarification submitted by a Proponent that is not in response to a request by the Lessor shall not be considered. The Lessor's request for clarification and the response shall be in writing. No change, including any voluntary increase or decrease, in the prices or substance of the proposal shall be sought, offered, or permitted, except to confirm the correction of arithmetic errors discovered by the Lessor in the evaluation of the proposals, in accordance with ITP 23.
	20.2	If a Proponent does not provide clarifications of its proposal by the date and time set in the Lessor's request for clarification, its proposal may be rejected.
<b>21. Deviations, Reservations, and Omissions</b>	21.1	During the evaluation of proposal, the following definitions apply:  (a) "Deviation" is a departure from the requirements

		<p>specified in the RFP Documents;</p> <p>(b) "Reservation" is the setting of limiting conditions or withholding from complete acceptance of the requirements specified in the RFP Documents; and</p> <p>(c) "Omission" is the failure to submit part or all of the information or documentation required in the RFP Documents.</p>
<b>22. Determination of Responsiveness</b>	22.1	The Lessor's determination of a proposal's responsiveness is to be based on the contents of the proposal itself, as defined in ITP 9.1.
	22.2	A substantially responsive proposal is one that meets the requirements of the RFP Documents without material deviation, reservation, or omission.
	22.3	<p>A substantially responsive proposal is one that meets the requirements of the RFP Documents without material deviation, reservation, or omission. A material deviation, reservation, or omission is one that,</p> <p>(a) if accepted, would</p> <p>(i) affect in any substantial way the scope, quality, or performance of the Works specified in the Contract; or</p> <p>(ii) limit in any substantial way, inconsistent with the RFP Documents, the Lessor's rights or the Proponent's obligations under the proposed Contract; or</p> <p>(b) if rectified, would unfairly affect the competitive position of other Proponents presenting substantially responsive proposal.</p>
	22.4	If a proposal is not substantially responsive to the requirements of the RFP Documents, it shall be rejected by the Lessor and may not subsequently be made responsive by correction of the material deviation, reservation, or omission.

<b>23. Correction of Arithmetical Errors</b>	23.1	<p>Provided that the proposal is substantially responsive, the Lessor shall correct arithmetical errors on the following basis:</p> <ul style="list-style-type: none"> <li>(a) if there is a discrepancy between the unit price and the total price that is obtained by multiplying the unit price and quantity, the unit price shall prevail and the total price shall be corrected, unless in the opinion of the Lessor there is an obvious misplacement of the decimal point in the unit price, in which case the total price as quoted shall govern and the unit price shall be corrected;</li> <li>(b) if there is an error in a total corresponding to the addition or subtraction of subtotals, the subtotals shall prevail and the total shall be corrected; and</li> <li>(c) if there is a discrepancy between words and figures, the amount in words shall prevail, unless the amount expressed in words is related to an arithmetic error, in which case the amount in figures shall prevail subject to (a) and (b) above.</li> </ul>
	23.2	<p>Proponents shall be requested to accept correction of arithmetical errors. Failure to accept the correction in accordance with ITP 23.1, shall result in the rejection of the Proposal.</p>
<b>24. Evaluation of Proposal</b>	24.1	<p>The Lessor shall use the criteria and methodologies listed in Section IV. Qualification and Evaluation Criteria.</p>
	24.2	<p>In the event, the difference in total evaluation scores of two or more Proponents is less than 3% the Proponent proposing the highest revenue (Net Present Value) will be ranked the highest among the Proponents with less than 3% and the rest of the Proponents within this range will be ranked accordingly.</p>
<b>25. Lessor's Right to Accept Any Proposal, and to Reject Any or All Proposal</b>	25.1	<p>The Lessor reserves the right to accept or reject any proposal, and to annul the RFP process and reject all proposals at any time prior to contract award, without thereby incurring any liability to Proponents. In case of annulment, all proposals submitted and specifically, bid securities, shall be promptly returned to the Proponents.</p>

*Handwritten signature or initials in blue ink.*

<b>D. AWARD OF CONTRACT</b>		
<b>26. Award Criteria</b>	26.1	Subject to ITP 25.1, the Lessor shall conditionally award the Contract to the Proponent(s) whose proposals has been determined to be substantially responsive to the RFP Documents and scored the highest marks as specified in ITP 24, provided further that the Proponent is determined to be qualified to perform the Contract satisfactorily.
	26.2	In case of multiple plots are specified in Section III, the Lessor shall conditionally award the Contract to the Proponents as per evaluation ranking subject to ITP 26.1
<b>27. Plot Selection</b>	27.1	Plot Selection for the Successful Proponents shall be carried out as per procedures <b>specified in the RFP data sheet.</b>
<b>28. Notification of Conditional Award</b>	28.1	Prior to the expiration of the period of proposal validity, the Lessor shall notify the successful Proponent, in writing, that its proposal has been accepted
	28.2	Until a formal contract is prepared and executed, the successful Proponents' proposal and the notification of conditional award shall constitute a binding Contract.
	28.3	Failure of the successful Proponent to fulfill the obligations mentioned in the Conditional Award Letter, or sign the Contract in accordance with ITP 29 shall constitute sufficient grounds for the annulment of the conditional award and forfeiture of the bid security. In that event the Lessor may award the Contract to the next highest evaluated Proponent whose offer is substantially responsive.
<b>29. Signing of Contract</b>	29.1	Promptly upon notification of the conditional award, the Lessor shall send the successful Proponent the Contract
	29.2	Within 07 (seven) days of the success fulfilment of the obligation stipulated in Conditional Award Letter, successful Proponent shall sign the Contract with Lessor.

**SECTION II. RFP DATA SHEET**

<b>A. GENERAL</b>	
ITP 1.1	Name of the Project: <b>Development and Operation of Channel Park Café / Restaurants in Hulhumale'</b>
ITP 1.1	The Reference Number of Proposal Process is: <b>HDC(161)-MKS/IU/2022/385</b>
ITP 3.2	Joint Venture share proportion restriction shall not apply.
<b>B. CONTENTS OF RFP DOCUMENTS</b>	
ITP 5.1	For <b>clarification purposes</b> only, the Lessor's address is:  <b>Marketing &amp; Sales</b> Housing Development Corporation Ltd. Ground Floor, HDC Building Hulhumalé, Maldives Tel: (+960)3355 314, (+960)3355 376 E-mail: <a href="mailto:sales@hdc.com.mv">sales@hdc.com.mv</a>
ITP 5.1	Webpage: Corporate website - <b>hdc.com.mv</b> MyHulhumalé Properties website - <b>properties.hdc.com.mv</b> Bids & Proposal Submission Portal - <b>bids.hdc.com.mv</b>
ITP 5.1	The deadline for request for clarification is on or before <b>18<sup>th</sup> September 2022 at 14:00hrs</b>
ITP 5.2	The <b>pre-proposal meeting</b> shall take place at the following date, time and place; Date: <b>14<sup>th</sup> September 2022</b> Time: <b>10:00hrs</b> Place: Online Meeting held via Zoom  Interested parties can join pre-proposal meeting via zoom link shared on Invitation for Proposals.  In order to minimize technical issues please join the meeting 10 minutes prior to the time.
<b>C. PREPARATIONS OF PROPOSALS</b>	
ITP 12.1	Proposal Validity Period: <b>150</b> (One Hundred and Fifty) days

ITP 13.1	<p>The Amount and Currency of Bid Security shall be <b>MVR 500,000.00</b> (Maldivian Rufiyaa Five Hundred Thousand) or <b>equivalent in United States Dollar (USD)</b>.</p> <p>The source of exchange rate shall be <b>Maldives Monetary Authority (MMA)</b> and the date for the exchange rate shall be 14 (fourteen) days before Proposal Submission deadline.</p>
ITP 13.2	<p>Bid Security Validity Period: <b>180</b> (One Hundred and Eighty) days from the deadline for submission of Proposals.</p>
<b>D. SUBMISSION AND OPENING OF PROPOSALS</b>	
ITP 15.1	<p>Proponents have the option of submitting their proposal electronically through Bids &amp; Proposal Submission Portal (<a href="https://bids.hdc.com.mv/">https://bids.hdc.com.mv/</a>).</p> <p>Proponent shall submit the required documents to the Bids &amp; Proposal Submission Portal before the deadline date specified in ITP 16.1. In order to submit the documents, proponent shall login via an Email address and Register as a Proponent.</p> <p>However, physical document of the Price Proposal Form and Bid Security shall be submitted to the Lessors Address at the Date and Time as specified in ITP 16.2. These documents will not be accepted through the portal.</p>
ITP 16.1	<p>For <b>online document submission purpose</b> only:</p> <p>Starting Date and Time: <b>22<sup>nd</sup> September 2022, 15:00hrs</b>          Deadline Date and Time: <b>02<sup>nd</sup> October 2022, 13:00hrs</b></p>
ITP 16.2	<p>For <b>proposal submission purpose</b> only, the Lessor Address is:</p> <p><b>Exhibition Center (Ground Floor)</b>          HDC Building          Huvandhumaa Hingun          Housing Development Corporation Ltd.</p> <p>Date: <b>02<sup>nd</sup> October 2022</b>          Time: <b>13:00hrs to 14:00hrs</b></p>
ITP 18.1	<p>For <b>proposal opening</b> shall take place at:</p> <p><b>Exhibition Center (Ground Floor)</b>          HDC Building          Huvandhumaa Hingun          Housing Development Corporation Ltd.</p> <p>Date: <b>02<sup>nd</sup> October 2022</b>          Time: <b>14:00hrs</b></p> <p><b><i>Proposal Opening will be held physically in front of the proponents participating at Proposal Opening.</i></b></p>



**E. AWARD OF CONTRACT**

ITP 27.1

Plot selection shall not apply.



### SECTION III. LESSOR'S REQUIREMENTS

#### 1. SCOPE OF WORK

Housing Development Corporation (Lessor) is seeking for interested parties for the development and operation of channel park café / restaurants. The selected parties (Lessee) will be responsible for the design, construction and operation of the plot for the duration of lease term as per the guidelines set forth by HDC. The operation of the plot includes but is not limited to, management, administration, supervision and maintenance of the plot.

#### 2. BUSINESS MODEL

- 2.1 The business model for the development is lease model.
- 2.2 The minimum acceptable lease rate per square feet per month for the plot are MVR 25 (Maldivian Rufiyaa Twenty-Five) for the first five years.
- 2.3 The lease rate proposed for each following year shall be equal or higher than the previous year's lease rate. Proposed lease rate which is less than the minimum acceptable lease rate shall be disqualified.
- 2.4 The Lessee shall propose the Acquisition Fee. The minimum acceptable Acquisition Fee for the Development of Channel Park Café / Restaurants is MVR 356.23 (Maldivian Rufiyaa Three Hundred Fifty-Six and Twenty-Three Laari) per square feet.
- 2.5 The Acquisition Fee proposed less than the minimum acceptable Acquisition Fee shall be disqualified.

#### 3. ESTIMATED PROJECT COST BY LESSOR

- 3.1 Estimated Project Cost by Lessor for the project is **MVR 3,747,168.02** (Maldivian Rufiyaa Three Million Seven Hundred Forty-Seven Thousand One Hundred Sixty-Eight and Two Laari).
- 3.2 The calculation basis for Estimated Project Cost by Lessor is calculated at the rate of MVR 334 (Maldivian Rufiyaa Three Hundred Thirty-Four) per sqft of Open Space Area and at the rate of MVR 3,000 (Maldivian Rufiyaa Three Thousand) for Buildable Area.



*[Handwritten signature]*

**4. PLOT DETAILS**

Lot Number	Usage	Unit Area
11674	Development and Operation of Café / Restaurants	3,237.03

*Drawings and Guideline related to the unit will be included in the Section VII. Drawings and Guidelines*

## SECTION IV. QUALIFICATION AND EVALUATION CRITERIA

This Section contains all the criteria that the Lessor shall use to qualify Proponents and evaluate the proposals. In accordance with ITP 24, no other factors, methods or criteria shall be used. The Proponent shall provide all the information / documents requested in the Section V, Business Proposal Requirements and proposal shall fulfill requirements in accordance with ITP 9.1.

### 1. QUALIFICATION CRITERIA

Proponents that meet the requirement set in Qualification Criteria of Section IV will be evaluated according to evaluation criteria.

#### 1.1. Financial Resources

- (a) Proponent shall provide proof of funds to finance the full Estimated Project Cost by the Lessor as per Section III. Lessor's Requirement, Clause 3.
- (b) Financial resources will be evaluated based on the method of financing proposed, and the documents submitted by the Proponents as per Section V. Business Proposal Requirement, Clause 4.
- (c) Proponents who do not show proof of funds to finance the proposed investment cost shall be disqualified.

#### 1.2. Outstanding Payment

- (a) Proponent shall not have any due payment to Lessor prior to 30 (Thirty) calendar days to Proposal Submission.
- (b) Proponents who have payment due prior to 30 (Thirty) calendar days of the submission of RFP shall be disqualified.

#### 1.3. History of Non-Performing Contracts and Compliance with Court Verdicts

- (a) Proponents whose agreement has been terminated due to Proponent's non-performance within last 5 (Five) years will be disqualified.
- (b) Proponents who do not have complied with any court verdicts in relation to an agreement made with HDC, within the last 5 (Five) years shall be disqualified.

#### 1.4. Single Party Exposure Limit

- (a) Proponents shall meet the criteria and requirements set forth in "Single Party Exposure Limit Policy" published as per announcement no: HDC(161)-CM/IU/2020/2017 dated on 13th October 2020 available at HDC corporate website and MyHulhumale' Properties website (refer to ITP 5.1).

## 2. EVALUATION CRITERIA

Proposals that meet the requirements set in Qualification Criteria of Section III will be evaluated based on the following evaluation criteria and points will allocated as below:

Criteria	Allocated %
a) Lease Rate & Acquisition Fee	70%
b) Experience	15%
c) Business Plan	15%
<b>Total</b>	<b>100%</b>

### 2.1. Lease Rate and Acquisition Fee - 70%

- 2.1.1. The Lease Rate and Acquisition Fee will be evaluated using the Net Present Value of the proposed Lease Rate and Acquisition Fee by the Proponent for the first five years after grace period.
- 2.1.2. Proponents with highest acceptable NPV and Acquisition Fee will be given the maximum score for the Lease rate and Acquisition Fee, whereby points shall be given as prorated for other Proponents.
- 2.1.3. NPV will be calculated as per the following formula with the discount rate of 10%

$$\sum_{0}^{n} \frac{I}{(1+r)^n}$$

n= number of years

I = rent proposed per month for each year starting from first year

r= discount rate (10%)

- 2.1.4. Lease rate and Acquisition Fee shall be proposed as per Section III Lessors' Requirement and proposals that are not in accordance Section III shall result in disqualification of proposal.

**2.2. Experience - 15%**

<b>Proponent Type</b>	<b>Operator</b>	<b>Developer</b>	<b>General Proponents</b>
<b>Operational Experience</b>	<b>65%</b>	<b>35%</b>	<b>50%</b>
a) If Similar Venture	- If More than 5 years' experience - maximum score allocated for operational experience of the respective proponent type - If Less than 5 years' experience - will be Prorated		
b) If general business venture	Maximum score will be capped at 60% of the total score allocated for operational experience of the respective proponent type -If More than 5 years' experience - 60% -If Less than 5 years' experience - will be Prorated from 60%		
c) Experience of the management and technical team (will only be considered if a member(s) of the management or technical team has a minimum of 2 years' experience in a managerial level position in a similar venture of business operation, or in a key role that is directly relevant to the primary purpose of the business)	50 % of maximum score will be allocated to the number of members in the management and technical team - if 1 (one) member with the said experience - 30% of 50% - if 2 (two) members with the said experience - 65% of 50% - if 3 (three) or more members with the said experience - 100% of 50%		
	50 % of maximum score will be allocated to the combined operational experience (in years) of the individuals in the management and technical team - if 20 (twenty) years' experience - 50% - if less than 20 (twenty) years' experience - prorated from 50%		
Marks for operational experience will be allocated to the Proponent in accordance with (a), (b), and (c), and whichever is higher will be considered as the score for operational experience			
<b>Proponent Type</b>	<b>Operator</b>	<b>Developer</b>	<b>General Proponents</b>
<b>Development Experience</b>	<b>35%</b>	<b>65%</b>	<b>50%</b>
a) Value of Completed Projects	- if completed projects are 150% and above of the project cost estimated by the lessor - maximum score allocated for development experience of the respective proponent type - if completed projects are less than 150% of the project cost estimated by the lessor - will be prorated		
b) Experience of the management and technical team (will only be considered if a member(s) of the management or technical team has a minimum of 2 years' experience in a managerial level position in a similar venture of business operation, or in a key role that is directly relevant to the primary purpose of the business)	50 % of maximum score will be allocated to the number of members in the management and technical team - if 1 (one) member with the said experience - 30% of 50% - if 2 (two) members with the said experience - 65% of 50% - if 3 (three) or more members with the said experience - 100% of 50%		
	50 % of maximum score will be allocated to the combined experience (in values of completed projects) of the individuals in the management and technical team - if completed projects are 150% and above of the project cost estimated by the lessor - 50% - if completed projects are less than 150% of the project cost estimated by the lessor - prorated from 50%		
Marks for development experience will be allocated to the Proponent in accordance with (a) and (b), and whichever is higher will be considered as the score for development experience			

### **2.3. Business Plan – 15%**

The business plan will be evaluated based on the following criterion:

- 2.3.1. Operational Plan – 10 points
- 2.3.2. Maintenance / Facilities Management Plan – 20 points
- 2.3.3. Financial Plan – 15 points
- 2.3.4. Marketing Plan – 20 points
- 2.3.5. Concept Design – 35 points

## SECTION V. BUSINESS PROPOSAL REQUIREMENT

To establish its qualifications to perform the contract in accordance with *Section IV Qualification and Evaluation Criteria* and to determine the proposal as substantially responsive proposal, Proponent shall provide the information requested in the corresponding documents included hereunder. Proponents are advised to submit the proposal in the following order and include page of content and separators for each section.

### 1. BID SECURITY AS IN FORM 01

### 2. LETTER OF PROPOSAL AS IN FORM 02

### 3. LEGAL DOCUMENTS:

- 3.1 Copy of Business Registration Certificate.
- 3.2 For Partnership: Partnership Deed / Agreement
- 3.3 For Company; Memorandum and Articles of Association of the Company.
- 3.4 For Company; Board Resolution of the Company confirming Board of Director's approval for proposed work.
- 3.5 Information of the Authorized Representative as in Form 03.
- 3.6 Declaration of Immediate Family Members as in Form 09
- 3.7 Power of Attorney to sign on behalf of the Proponent in accordance with ITP 14.2.
- 3.8 In the case of a Proposal submitted by a Joint Venture (JV), the JV agreement or letter of intent to enter into JV including but not limited to scope of works to be executed by respective partners and equity share percentage of the respective partners;

### 4. FINANCIAL DOCUMENTS

- 4.1. HDC statement of the Due Clearance
  - 4.1.1. Due clearance statement from HDC will be given upon request from the proponent via Due Clearance Form.  
  
Due Clearance Form will be available to download from:  
<https://hdc.com.mv/downloads/>
- 4.2. Financing Method(s) as in Form 04
  - 4.2.1 Proposed method(s) of financing the Estimated Project Cost and the percentage ratio of method (s). Proposed method(s) of financing for investment can be equity financing, equity injection, bank finance, external finance such as financier company, lines of credit, time deposit, tradable bonds or combination of various financing methods.





**4.3 Based on the proposed method of Financing, the following documents are required:****4.3.1 Equity Financing by a Sole Proprietorship:**

- (a) Monthly Average Balance Confirmation of the most recent 12 (twelve) months of the business entity shall be submitted. The submitted statement shall be original, authorized and sealed by the bank / financial institution.

**4.3.2 Equity Financing by a Company:**

- (a) Monthly Average Balance Confirmation of the most recent 12 (twelve) months of the business entity shall be submitted. The submitted statement shall be original, authorized and sealed by the bank / financial institution.
- (b) For Company, audited financial statements of most 03 recent year (2021, 2020, 2019) authorized by a certified audit firm / individual and management account of the year 2022. The audited financial statements must include auditors report and shall be signed and stamped by the respective parties. It is not a requirement to submit Audited Financial statements, if the company is not audited as per MIRA requirements.

**4.3.3 Bank Financing:**

- (a) Bank comfort letter/bank guarantee or any other relevant documents from bank or financial institutions shall be submitted. The submitted documents shall include the Proponent(s) name and name of proposed work/ project (RFP Name).

**4.3.4 Equity Injection:**

- (a) Letter of commitment from shareholder including the Proponent(s) name and name of the proposed work/ project (RFP Name).
- (b) Shareholder's monthly end balance statement (as per Section V Clause 4.3.1 (a)) or shareholder's audited financial statements (as per Section V Clause 4.3.2 (b)) or relevant documents for bank financing by shareholder (as per Section V Clause 4.3.3) or relevant documents for external financing by shareholder (as per Section V Clause 4.3.5) shall be submitted.

**4.3.5 External Financing:**

- (a) Letter of commitment from financier including the Proponent(s) name and name of the proposed work/ project (RFP Name).
- (b) Financier's monthly end balance statement (as per Section V Clause 4.3.1 (a)) or financier's audited financial statements (as per Section V Clause 4.3.2 (b)) or relevant documents for bank financing by financier (as per Section V Clause 4.3.3) shall be submitted.

## 5. EXPERIENCE

- 6.1 Proponent shall mention in the price proposal whether the proponent is submitting the proposal as the Contractor, Operator or as a General Business.
- 6.2 Proponents shall submit verifiable documents proving their experience including project completion letters / certificate including project values, reference letter or any other relevant documents proving the experience in the field or similar business activities.
- 6.3 Proponents are required to submit documents according to Form 06 for the Project Completion Letter / certificate and Form 07 for reference letter.
- 6.4 If the experience of the Management and Technical Team is proposed, Proponent shall submit management and technical team profile which shall include name, designation and current/past experience of the member with verifiable supporting documents. Further, if the development experience of the Management and Technical Team is proposed, reference letters shall include the participation of the member. These letters shall include the project value.

## 6. BUSINESS PLAN

The proponent shall submit a business plan including:

### 6.1 Operational Plan

- 6.1.1 The project management team structure
- 6.1.2 Management and operational details of café

### 6.2 Maintenance / Facilities Management Plan

- 6.2.1 Proposed maintenance / facilities management structure
- 6.2.2 Proposed management fee structure

### 6.3 Financial Plan

- 6.3.1 Project financing mechanism
- 6.3.2 Financial forecast

### 6.4 Marketing Plan

- 6.4.1 Product strategy including target market & product alignment with Hulhumale' Master Plan
- 6.4.2 Pricing strategies
- 6.4.3 Promotional Strategies

### 6.5 Concept Design

#### 6.5.1 Clarity of Concept

- 6.5.1.1 Clarity of proposed idea
- 6.5.1.2 Relevance of the brief and business model
- 6.5.1.3 Translation of concept to design

**6.5.2 Site responsive design**

6.5.2.1 Addressing the surrounding natural and built-up context

6.5.2.2 Site circulation and accessibility

**6.5.3 Function oriented design**

6.5.3.1 Space programming and catering to the needs of users

6.5.3.2 Adaptability and flexibility

6.5.3.3 Circulation and operation efficiency in the arrangement of spaces

**6.5.4 Materiality and Buildability**

6.5.4.1 Longevity and building

6.5.4.2 Accessible material

6.5.4.3 Maintenance and upkeep for the development in the long run

**7. PROPOSAL CHECKLIST**

7.1 Proposal Checklist as in Form 07 should be attached outside the sealed envelope.



*[Handwritten signature]*

**FORM 01: BID SECURITY FORM**

The Issuing Bank shall fill in this Bank Security Form in accordance with the instructions indicated.

\_\_\_\_\_ {Bank's Name, and Address of Issuing Branch or Office}

**Beneficiary.:** Housing Development Corporation Ltd., 3rd Floor, HDC Building, Hulhumalé, Republic of Maldives,

**Date.:** \_\_\_\_\_

**Bid Security No.:** \_\_\_\_\_

We have been informed that \_\_\_\_\_ {name of the proponent} (hereinafter called "the Proponent") has submitted their proposal dated \_\_\_\_\_ {date of proposal submission} for the execution of \_\_\_\_\_ {name of project} (hereinafter called "the RFP") under Invitation for Proposal No. \_\_\_\_\_ {invitation for proposal}.

Furthermore, we understand that, according to your conditions, Proposals must be supported by a Bid Security.

At the request of the Proponent, we \_\_\_\_\_ {name of Bank} hereby irrevocably undertake to pay you any sum or sums not exceeding in total an amount of \_\_\_\_\_ [amount in figures] (\_\_\_\_\_ [amount in words]) upon receipt by us of your first demand in writing accompanied by a written statement stating that the Proponent is in breach of its obligation(s) under the RFP conditions, because the Proponent:

- (a) has withdrawn its Proposal during the period of Proposal validity specified by the Proponent in the Letter of Proposal; or
- (b) having been notified of the acceptance of its Proposals by the Employer during the period of Proposal validity, (i) fails or refuses to pay lease deposit, or (ii) fails to execute the term and conditions of the conditional award of the Employer.

This guarantee will expire: (a) if the Proponent is the successful Proponent, upon our receipt of copies of the agreement signed by the Proponent and the lease deposit furnished to you upon the instruction; and (b) if the Proponent is not the successful Proponent, upon the earlier of (i) our receipt of a copy of your notification to the Proponent of the name of the successful Proponent; or (ii) **180 (One Hundred and Eighty)** calendar days from {date of submission} of the Proposal for the RFP.

Consequently, any demand for payment under this guarantee must be received by us at the office on or before that date.

This guarantee is subject to the Uniform Rules for Demand Guarantees, ICC Publication No. 458  
**[seal and signature of the bank / financial institution]**



**FORM 02: LETTER OF PROPOSAL**

Date: .....

Name of the Project: .....

Proposal Reference No: .....

Proponent Type:  Contractor  
 Operator  
 General

**To:** Housing Development Corporation Ltd.  
Ground Floor, HDC Building  
Hulhumalé, Maldives

We, the undersigned, declare that:

- (a) We have examined and have no reservations to the Request for Proposal (RFP) documents including all addenda issued in accordance with Instruction to Proponents (ITP) 6.
- (b) We meet the eligibility requirements and have no conflict of interest in accordance with ITP 3;
- (c) We have not been suspended nor declared ineligible by the Lessor in accordance with ITP 3.3.
- (d) We have no outstanding payment due to the Lessor in accordance with Section III.
- (e) We have no non-performance of a contract and non-compliance with court verdicts in accordance with Section III.
- (f) We, (insert *business name and business registry number*), offer to (insert name of the Project).
- (g) We undertake, to pay the proposal Acquisition Fee, where the proposal is accepted. The proposed Acquisition Fee rate per square feet is: MVR.....L..... (amount in numbers) Rufiyaa..... Laari.....) (amount in words).
- (h) We undertake, to pay the proposed Lease rate for 05 (five) years, where proposal is accepted. The lease rate is:
  - 1<sup>st</sup> Year (per square feet per month): MVR ..... L ..... (*amount in numbers*)  
(Rufiyaa .....Laari.....) (*amount in words*)
  - 2<sup>nd</sup> Year (per square feet per month): MVR ..... L ..... (*amount in numbers*)  
(Rufiyaa .....Laari.....) (*amount in words*)
  - 3<sup>rd</sup> Year (per square feet per month): MVR ..... L ..... (*amount in numbers*)  
(Rufiyaa .....Laari.....) (*amount in words*)
  - 4<sup>th</sup> Year (per square feet per month): MVR ..... L ..... (*amount in numbers*)



(Rufiyaa .....Laari.....) (amount in words)

5<sup>th</sup> Year (per square feet per month): MVR ..... L ..... (amount in numbers)

(Rufiyaa .....Laari.....) (amount in words)

- (i) Where the proposal is successful, we undertake, to adhere the Drawings and Guidelines stated in Section VII, during the design and construction of the development / Unit.
- (j) Our proposal shall be valid for a period of One Hundred and Fifty (150) days from the date of proposal submission deadline in accordance with RFP document and it shall remain binding upon us and may be accepted at any time before the expiration of that period.
- (k) We understand that this proposal, together with your written acceptance thereof included in your notification of award, shall constitute a binding contract between us, until a formal contract is prepared and executed; and
- (l) We understand that Lessor is not bound to accept the highest evaluated proposal or any proposal that the lessor may receive.

**Proponent:**

Name: .....

(Seal)

Address: .....

Duly authorized to sign the proposal for and on behalf of the Company:

Name: .....

Title: .....

Signature: .....

Date: .....



**FORM 03: INFORMATION OF THE AUTHORIZED REPRESENTATIVE**

Date: .....

Proposal Reference No:.....

**To:** Housing Development Corporation Ltd.  
Ground Floor, HDC Building  
Hulhumalé, Maldives

This is to authorize (*Name, ID number*) as a representative of (*Name of the Proponent*) to carry out the Project related to RFP (ref no) and to liaise with Lessor on behalf of the (*Name of the Proponent*)

**Proponent:**

Name: .....

Address: .....

.....

*Signature and Stamp*

**Authorized Representative (preferably fulltime personal):**

Name: .....

Designation: .....

ID Number: .....

Contact Number: .....

Email Address: .....

.....

*Signature*



A handwritten signature in blue ink, appearing to be 'S. S.', with a small mark below it.

**FORM 04: FINANCING METHOD(S)**

Date: .....

Name of the Project: .....

Proposal Reference No:.....

**To:** Housing Development Corporation Ltd.  
Ground Floor, HDC Building  
Hulhumalé, Maldives

Where the proposal is successful, we undertake, to finance the project/work under:

..... (Method of financing) ..... (percentage ratio)

..... (Method of financing) ..... (percentage ratio)

..... (Method of financing) ..... (percentage ratio)

..... (Method of financing) ..... (percentage ratio)

We hereby confirm and agree to finance the project/work will be financed by the above mentioned method(s). We have submitted relevant documents to provide proof of funding, to the proposed method(s) of financing the project/work. We understated that the proposal will be disqualified if the documents do not show proof of funds to finance the Estimated Project Cost or if the documents are not in accordance with Section V. Business Proposal Requirement Clause 4. Financial Documents.

**Proponent:**

Name: .....

Address: .....

.....

*Signature and Stamp*





**FORM 05: FORMAT FOR PROJECT COMPLETION CERTIFICATE**

[INSERT PROPONENT LETTER HEAD]

**PROJECT COMPLETION CERTIFICATE**

1. **Project:** *[Insert Completed Project Name] [Insert Building Name /Lot Number]*
2. **Agreement No:** *[Insert Agreement Number] [Insert Agreement Date]*
3. **Client:** *[Insert Company Name of The Developer/ Contractor]*  
*[Insert ID Card No / Business Registration No]*  
*[Insert Company Name of The Developer/ Contractor]*
4. **Contractor:** *[Insert Company Name of The Developer/ Contractor]*  
*[Insert Registration No:]*  
*[Insert Address]*
5. **Project Information:**  
**Total Project Value:** *[insert project value in Maldivian Rufiyaa MVR]*  
**Start Date:** *[insert project start date]*  
**Completion Date:** *[insert project completion date]*  
**Any Additional details of the Completed Project:** (construction area, floor height)

The project was awarded to *[Insert Developer/Contractor Name]* for the *[Insert Project Name]* and the project was completed and handed over to *[Insert Client Name]* on *[Insert Completion / Handover Date]*.

**[Signature On Behalf of The Developer/Contractor]**

Name: .....

Company Registration No. : .....

Designation: .....

Signature: .....

Seal: .....



I hereby confirm and certify that work under the above-named project *[Insert Project Name]* has been satisfactorily executed and completed by *[Developer / Contractor Name]*

**[Signature On Behalf of The Client]**

Name: .....

Company Registration No. : .....

ID Card No:.....

Contact No: .....

Signature: .....

Seal: .....

---

Include a copy of ID Card copy of the client or Copy of Company Registration of the Client



**FORM 06: FORMAT FOR REFERENCE LETTER**

*[Insert Client Letter Head]*

*[Client Name]*

*[Client Address]*

*[Client Contact No.]*

*[Client Email]*

Date: *[Insert Date]*

Reference No: *[Insert Reference Number]*

**TO WHOM IT MAY CONCERN**

This letter of reference is issued to *[insert Proponent Name]* for the *[insert work/service name]*. We confirm with our best knowledge that *[Insert Proponent Name]* has satisfactorily completed *[insert work / service name]* from *[start date]* and to *[completion date]* and the value of the work completed was *[insert value of work/service completed in Maldivian Rufiyaa MVR]*

*[Optional] [Insert Proponent Name] carried out [insert scope of work/services or brief description of the work/services].*

We recommend the *[work/services]* of *[Insert Proponent Name]* and endorse the credibility and the professionalism of their services.

Should you require any further queries on the above references, please feel free to contact me.

Sincerely,

*[Sign]*

*[Signatory Name]*

*[Designation]*

---

Include a copy of ID Card copy of the client or Copy of Company Registration of the Client



**FORM 07 - PROPOSAL CHECKLIST**

Proponents are required to submit Form 07 – Proposal Checklist outside the sealed envelope of the Proposal

Proponent	For HDC use	
<input type="checkbox"/>	<input type="checkbox"/>	1. Bid Security as in FORM 01
<input type="checkbox"/>	<input type="checkbox"/>	2. Letter of Proposal as in FORM 02
<input type="checkbox"/>	<input type="checkbox"/>	3. Copy of Business Registration Certificate
<input type="checkbox"/>	<input type="checkbox"/>	4. Board Resolution as in SECTION IV 3.4
<input type="checkbox"/>	<input type="checkbox"/>	5. Proposal Checklist in FORM 07 attached outside sealed proposal.

**NOTE:**

- **PROPOSALS WITHOUT THE SPECIFIED DOCUMENTS STATED IN THE FORM 07 PROPOSAL CHECKLIST (EXCLUDING FORM 07 - PROPOSAL CHECKLIST) WILL BE REJECTED AT THE TIME OF PROPOSAL OPENING.**
- **ANY BANK STATEMENTS WILL NOT BE ACCEPTED WITH THE PROPOSAL. REQUIRED FINANCIAL DOCUMENTS MUST BE SUBMITTED AS PER CLAUSE 4 (FINANCIAL DOCUMENTS) OF SECTION V. BUSINESS PROPOSAL REQUIREMENT.**



*[Handwritten signature]*

**FORM 08 - PROPONENTS CHECKLIST**

Proponents shall confirm that all the required documents are submitted along with the proposals submitted. Proponents Checklist shall be checked and signed by the Proponent and shall be submitted along with the proposal.

<b>Proposal Documents:</b>	
	Price Proposal Form
	Bid Security
	Business Plan
<b>Legal Documents:</b>	
Sole Proprietors:	
	Business Registration Certificate
	Information of the Authorized Representative as in Form 03
	Power of Attorney to sign on behalf of the Proponent
Companies:	
	Business Registration Certificate
	Information of the Authorized Representative as in Form 03.
	Power of Attorney to sign on behalf of the Proponent
	For Partnership: Partnership Deed / Agreement
	Memorandum and Articles of Association of the Company
	Board Resolution of the Company confirming Board of Director's approval for proposed work
<b>Financial Documents:</b>	
	HDC statement of the Due Clearance
	For sole proprietors: monthly average balance confirmation of last 12 months and sealed by bank/financial institution
	For companies: Audited Financial statements of the most recent 03 (three) years or monthly average balance confirmation of last 12 months and sealed by bank/financial institution
<u>Documents required based on the proposed Method of Financing:</u>	
<u>If Equity Financing is proposed:</u>	
	Monthly average balance confirmation of last 12 months and sealed by bank/financial institution
	For companies; Audited Financial statements of the most 03 recent year (2021, 2020,2019) or monthly average balance confirmation of last 12 months and sealed by bank/financial institution
<u>If bank financing is proposed:</u>	
	Bank Comfort letter
<u>For equity injection:</u>	
	Commitment letter from shareholders
	Average monthly balance of the past 12 months authorized and sealed by bank/financial institution of the shareholders (OR) Audited Financial statements of the most recent year (2021) and management account of the year 2021 (OR) Relevant documents for bank financing by shareholder Relevant documents for external financing by shareholder
<u>For external financing:</u>	



	Commitment letter of the financier
	Average monthly balance of the past 12 months authorized and sealed by bank/financial institution of the external financier (OR) Audited Financial statements of the most recent year (2021) and management account of year 2022 (OR) Relevant documents for bank financing by financier

We hereby confirm that we have submitted the above-mentioned documents along with the proposal. We understand that the proposal will be disqualified if the documents are not in accordance with Section V. Business Proposal Requirement.

**Proponent:**

Name: .....

Address: .....

.....

*Signature and Stamp*



*[Handwritten signature]*

**FORM 09 - DECLARATION OF IMMEDIATE FAMILY MEMBERS**

Date: .....  
 Name of the Project: .....  
 Proposal Reference Number: .....  
 Proponent Name: .....  
 Name of the Authorized Signatory: .....

We, **[insert business name and business registry number]**, hereby confirm and declare that;

1. has a relation (Immediate family members/relatives employed at HDC) that puts in a position to influence the proposal of the proponent, or influence the decisions of the Lessor regarding the RFP process, (Yes/No)
2. If Yes, specify the details relating to the information pursuant to Clause 1 above are as follows;

NID No.	Family member / Relatives Name	Relationship	Position/Title

3. I hereby confirm the following:
  - a. That the information above is true, accurate and if all or any part of them are found to be untrue, HDC shall have the right to disqualify and reject the bid/proposal/quotation or terminate the agreement/work order,
  - b. I am also obliged to inform and disclose to HDC if there are any changes to the declaration herein, within ten (10) days from the occurrence of such changes.

Name: .....  
 Date: .....

Signature



*[Handwritten signature]*

**SECTION VI. CONTRACT TERMS**

1.	<b>Parties to the Agreement</b>	<p>Housing Development Corporation Ltd</p> <p>HDC Building</p> <p>Hulhumalé</p> <p>(hereinafter referred to as "lessor", which expression shall include its successors-in-title, liquidators, administrators and lawful assignees where the context so requires or admits).</p> <p>[Address of the successful Proponent]</p> <p>(hereinafter referred to as "lessee", which expression shall include its successors-in-title, liquidators, administrators and lawful assignees where the context so requires or admits)</p>
2.	<b>Objective</b>	2.1. To allocate land for the Development and Operation of a Channel Park Café / Restaurant
3.	<b>Land Usage</b>	<p>3.1. The land shall be utilized for the development and operation of a Channel Park Café / Restaurant.</p> <p>3.2. Any other land use apart from the intended land uses are prohibited in the allocated land plot.</p> <p>3.3. Any development on the land should be in compliance with the Hulhumale' Planning and Development guidelines.</p>
4.	<b>Land Detail</b>	<p>4.1. Lot Number: 11674</p> <p>4.1.1 Plot Area: 3,237.03 sq. ft</p> <p>4.1.2 Buildable area: 1,000.00 sq. ft</p>
5.	<b>Lease Terms</b>	<p>5.1 Lease term: 20 (twenty) years</p> <p>5.2 The lease rate per month for the first five years will be the proposed lease rate of the winning proposal.</p> <p>5.3 The lease rate will be revised in every first five years based on market inflation <math>P(1+i+5\%)</math> where; P = monthly lease rate for the preceding year, and i= cumulative inflation for the five years which will be real estate inflation for the Male' area in the MMA statistics reports.</p> <p>5.4 The lease rate will be effective from agreement signing date.</p>
6.	<b>Conditions Precedent</b>	<p>6.1 Agreement will only be signed upon the fulfillment of the following conditions:</p> <p>6.1.1 Submission of Performance Guarantee as per clause 7</p> <p>6.1.2 Payment of Acquisition Fee as per 8</p> <p>6.1.3 Submission and Approval of Concept Drawing as per clause 9</p>
7.	<b>Performance Guarantee</b>	7.1 Submission of Performance Guarantee amounting to 5% of the Project Value, shall be paid to HDC within 30 (thirty) Calendar Days of Conditional Award letters. However, the





		<p>Performance Guarantee amount is subjected to the following;</p> <p>7.1.1 For Local Parties: 5% of the estimated project value.</p> <p>7.1.1.1 If 5% of the Estimated Project Cost is less than MVR 500,000.00 the party shall pay a Performance Guarantee of MVR 500,000.00. If 5% of the Estimated Project Cost is more than MVR 5,000,000.00 the party shall pay a Performance Guarantee of MVR 5,000,000.00.</p> <p>7.1.2 For International Parties: 5% of the Estimated Project Cost.</p> <p>7.1.2.1 If 5% of the Estimated Project Cost is less than USD 100,000.00 the party shall pay a Performance Guarantee of USD 100,000.00. If 5% of the Estimated project Cost is more than USD 1,000,000.00 the party shall pay a performance Guarantee of USD 1,000,000.00</p> <p>7.2 The Performance Guarantee should be valid throughout the development period plus 03 (three) additional calendar months from completion of development.</p> <p>7.3 In case of Agreement termination within the development period, Lessee has the right to claim Performance Guarantee.</p>
8.	<b>Acquisition Fee</b>	<p>8.1 The Acquisition Fee is the proposed Acquisition Fee by the Proponent.</p> <p>8.2 Acquisition fee shall be paid from 30 days of Conditional award letter.</p>
9.	<b>Concept Drawings</b>	<p>9.1 The Lessee shall submit concept drawings as per the Hulhumale' development guidelines, within 30 (thirty) calendar days from the receipt of Conditional Award letter.</p> <p>9.2 If the submitted concept drawing is as per the development guidelines, Lessor must provide the approval within 14 (fourteen) working days from the submission date.</p> <p>9.3 If the submitted concept design is not as per the development guidelines, Lessor must provide comments to the Lessee within 14 (fourteen) working days from submission.</p> <p>9.4 Lessee must ensure rectifications are made as per the comments of HDC and submit within 14 (fourteen) working days of HDC's comments being communicated, failing to do so will result in cancelation of the Conditional Award letter.</p> <p>9.5 Revised concept cannot be submitted prior to receiving</p>

		<p>comments from HDC.</p> <p>9.6 The Lessee will have to address all issues highlighted in comments for drawings prior to submission of revised concept.</p> <p>9.7 If the concept is changed / revised and resubmitted for approval, after the initial approval has been given, the developer will be charged a review fee of MVR 03.00 (Maldivian Rufiyaa Three) per square meter.</p> <p>9.8 The Lessor must inform in writing to the Lessee of the approval or rejection of the revised concept drawings submitted.</p>
10.	<b>Detailed Drawings</b>	<p>10.1 Lessee must submit the detailed drawings, as per the approved concept and Hulhumalé Development guidelines within 60 (sixty) calendar days of Agreement signing date.</p> <p>10.2 If the submitted detailed drawings is as per the approved concept and Hulhumalé development guidelines, HDC must provide the approval within 14 (fourteen) working days of submission date.</p> <p>10.3 If the submitted detailed drawings in not as per the approved concept drawings and Hulhumalé development guidelines HDC must provide the comments within 14 working days with a 14 (fourteen) calendar days period to Lessee to submit revised drawings as per the comments.</p> <p>10.4 If the Lessee fails to get approval for the detailed drawings with the second submission, HDC will consider it as failure to fulfill the condition and will lead to the termination of the Agreement.</p> <p>10.5 HDC will charge the Lessee as per HDC's drawings approval fee at the time of detailed drawings approval and the approval will be released upon Lessee making the payment</p>
11.	<b>Lease Deposit</b>	<p>11.1 The lease deposit amount shall be the total of first 03 (three) months lease</p> <p>11.2 This amount shall be paid within 07 (seven) working days of detailed drawing approval and prior to the land handover</p> <p>11.3 The Lessor will keep the lease deposit throughout the Agreement period</p> <p>11.4 Lease deposit will be paid back within 01 month upon expiration of the agreement after adjusting for any unpaid lease, penalty or expenses that Lessor may incur linked to the Agreement and the land, such as but not limited to unpaid utility bills, etc.</p> <p>11.5 If the Agreement is terminated by the Lessee before the expiration of the Agreement term without the notice period specified under clause 21.3, Lessor has the right to take the</p>

*Handwritten signature*

		lease deposit amount in full.
12.	<b>Land Handover</b>	<p>12.1 The land will be handed over to the lessee within 07 (seven) calendar days of detailed drawings approval.</p> <p>12.2 The land will be handed over to the Lessee on an "as where is basis". i.e.: in its current condition at the date of agreement signing. However, the Lessor should ensure that the land is free from any legal encumbrances.</p>
13.	<b>Grace Period</b>	13.1 The Lessee will be given maximum of 10 (ten) months lease free period from the date of Agreement signing.
14.	<b>Time Line</b>	<p>14.1 Construction duration is maximum 10 (ten) months from the date of Agreement signing.</p> <p>14.2 Lessee must submit detailed drawings within 60 calendar days of Agreement signing.</p> <p>14.3 HDC must hand over the land to the Lessee within 7 (seven) calendar days after the Lease Deposit payment.</p> <p>14.4 Lessee must submit, if required by relevant authorities, approved EIA report within 30 (thirty) calendar days of detail drawing approved date.</p> <p>14.5 Lessee must submit project plan and schedule timeline within 30 (thirty) calendar days from date of approval of detailed drawings</p> <p>14.6 Lessee must submit the Bill of Quantity (BOQ) including the cost and manpower plan within 30 (thirty) calendar days from the date of approval of the detailed drawings.</p> <p>14.7 Lessee must start the usage of the building or commence the intended operation within 30 (thirty) calendar days after the issuance of building usage permit by HDC</p>
15.	<b>Mortgage Rights</b>	15.1 Mortgage rights of the land can be given to Lessee as per HDC's Mortgage Policy.
16.	<b>Operation &amp; Management</b>	<p>16.1 The Lessee shall be responsible for the administration, supervision and management of the Channel Park Café / Restaurant.</p> <p>16.2 The Lessee must ensure continued operation and provision of service to the public throughout the Agreement period.</p> <p>16.3 Failure to provide a continuous / regular service as per clause 20, by the Lessee will be considered as a breach of contract.</p> <p>16.4 The Lessee must ensure that the Land/Property is maintained up to safety standards specified by the relevant authorities such as, but not limited to, MNDF fire and safety standards</p> <p>16.5 The Lessee must ensure the Security of the land/property at all times</p> <p>16.6 The Lessee must ensure property maintenance of the land/property throughout the Agreement duration</p>

		16.7 The Lessee must ensure that the property is insured throughout the Agreement period. Such an insurance should at least cover the losses including third party losses due to fire.
17.	<b>Independent Consultant</b>	17.1 The Lessee shall appoint a licensed independent consultant until the completion of the project. The independent consultant shall report to HDC.
18.	<b>Request for Extension</b>	18.1 An extension for the project schedule should be applied no later than 20% of the allowed time remaining 18.2 With any extension request, the proponent must submit a revised project schedule backed by a resource plan and signed by the independent consultant proving that the developer will be able to achieve the targeted completion deadline. 18.3 The terms of the extension would be at sole discretion of the Lessor. 18.4 Any request to extend shall be submitted with proper proof of documents for HDC to grant any extension.
19.	<b>Penalty</b>	19.1 A penalty of 0.01% of the Estimated Project Cost per day will be levied on any extension to the deadline of completion of construction and finishing works. 19.2 If any damage is caused to the public infrastructure or HDC property due to the act of or negligence of the lessee, penalty between MVR 50,000 (Maldivian Rufiyaa Fifty Thousand) to MVR 100,000 (Maldivian Rufiyaa Hundred Thousand) should be applied along with actual cost of repair to the said damage.
20.	<b>Failure to provide Product/Service</b>	20.1 In case the Lessee fails to provide the services as agreed, will result in a penalty. 20.1.1 Failure to provide the service means interruption of the service for a duration of 2 week without a force majeure event. 20.1.2 Interruption for repair and maintenance required under regulations and for safety will not be considered as service interruption, however the Proponent should inform to HDC of such interruption and get written approval for such duration. 20.2 The Lessee will be penalized by 5% of the monthly lease amount and should be paid with next monthly lease payment. 20.3 Agreement will be terminated if the interruption period exceed 3 consecutive months
21.	<b>Termination</b>	21.1 If the Lessee fails to perform any of its obligations under the Agreement, the Lessee shall be granted a period to rectify



		<p>the breach along with a fine amount between MVR 5,000 (Maldivian Rufiyaa Five Thousand) and MVR 100,000 (Maldivian Rufiyaa Hundred Thousand) considering the degree of the breach, to be determined by the sole discretion of the Lessor.</p> <p>21.2 If the Lessee fails to pay the fine and cure the breach within the extension period, the Lessor has the right to terminate the Agreement and give the Lessee a duration of not less than 30 (thirty) calendar days to vacate the land and handover the land to the Lessor</p> <p>21.3 The Lessee may terminate the Agreement by serving 6 (six) months' written notice upon the Lessor of its intention to do so for any reason whatsoever.</p> <p>21.4 If any development has been undertaken at the time of termination, the development will be valued at cost by an independent valuer.</p> <p>21.5 If the Lessee fails to achieve any hard deadlines by 150% HDC will terminate the Agreement, under no circumstances this clause should be taken as an automatic time extension to any hard deadlines given in the Agreement.</p> <p style="padding-left: 40px;">21.5.1 For example, if the deadline for the submission of detail drawings is 90 days from agreement signing, however for any reason if the drawings are submitted later then <math>(90 \times 150\%)</math> 135 (one hundred and thirty-five) days from agreement signing.</p> <p>21.6 If for any reason if the Lessee is penalized and the total accumulated penalty amount exceeds 20% of the project value, HDC has the right to terminate the Agreement.</p>
<p><b>22.</b></p>	<p><b>Process of agreement Termination</b></p>	<p>22.1 Upon agreement termination, HDC shall claim any Performance Guarantee submitted in relation to the agreement.</p> <p>22.2 Upon agreement termination, the Lessee must give the ownership of the approved drawings to HDC, under the Agreement.</p>
<p><b>23.</b></p>	<p><b>Formalities Effecting Termination</b></p>	<p>23.1 Upon termination HDC will take the possession of any immovable assets on the land.</p> <p>23.2 Any such assets should be valued at cost based on the BOQ and the work done.</p> <p>23.3 HDC can allocate the development to a new Lessee via an open RFP process, EOI process or any other allocation method that is in place.</p> <p>23.4 When opening up for RFP, HDC should include a base acquisition cost which is agreeable to both parties but not higher than the cost value of the asset.</p> <p>23.5 Once the development is successfully allocated to a new</p>

*Handwritten signature*

		<p>party and Acquisition Cost is fully recovered, HDC should pay to the party 80% of the Acquisition Cost with a maximum of the cost as per clause 23.2</p> <p>23.6 HDC can take 20% and any amount above the cost value as a compensation for the administrative work and lost time</p> <p>23.7 In case, HDC fails to secure a new party through an open RFP process, EOI process or any other allocation method that is in place, the existing developer will not be entitled to any compensation and has to vacate the premises upon termination.</p>
24.	<b>Definitions</b>	<p>24.1 Development period: Development period means duration from Agreement signed date to the date of commencing the usage of the development for the intended purpose.</p> <p>24.2 Construction Period: Construction period is the duration from land handover to the date of completion of the construction and finishing works.</p> <p>24.3 Hard Deadlines: Hard deadlines are the deadlines for the following tasks:</p> <p style="padding-left: 40px;">24.3.1 Date for the submission of the detailed drawings</p> <p style="padding-left: 40px;">24.3.2 Date for the completion of the construction and finishing works</p> <p>24.4 HDC delays: HDC delays mean any delays from HDC side in providing any comments or approval or land handover, in such a case HDC should revise the deadlines accordingly.</p>

**DISCLAIMER:**

- **This contract terms only includes the key points of the agreement. The agreement is not limited to the clauses included in this contract terms.**
- **The proposal submitted by the successful Proponent shall be a part of the agreement.**

## SECTION VII. DRAWINGS AND GUIDELINES

### 1. DRAWINGS

The drawing contains the location map and plot/unit map of the unit to be allocated for the development.

\* Areas in the drawings is subjected to minimal changes.

(Refer to next page)



PHASE 1

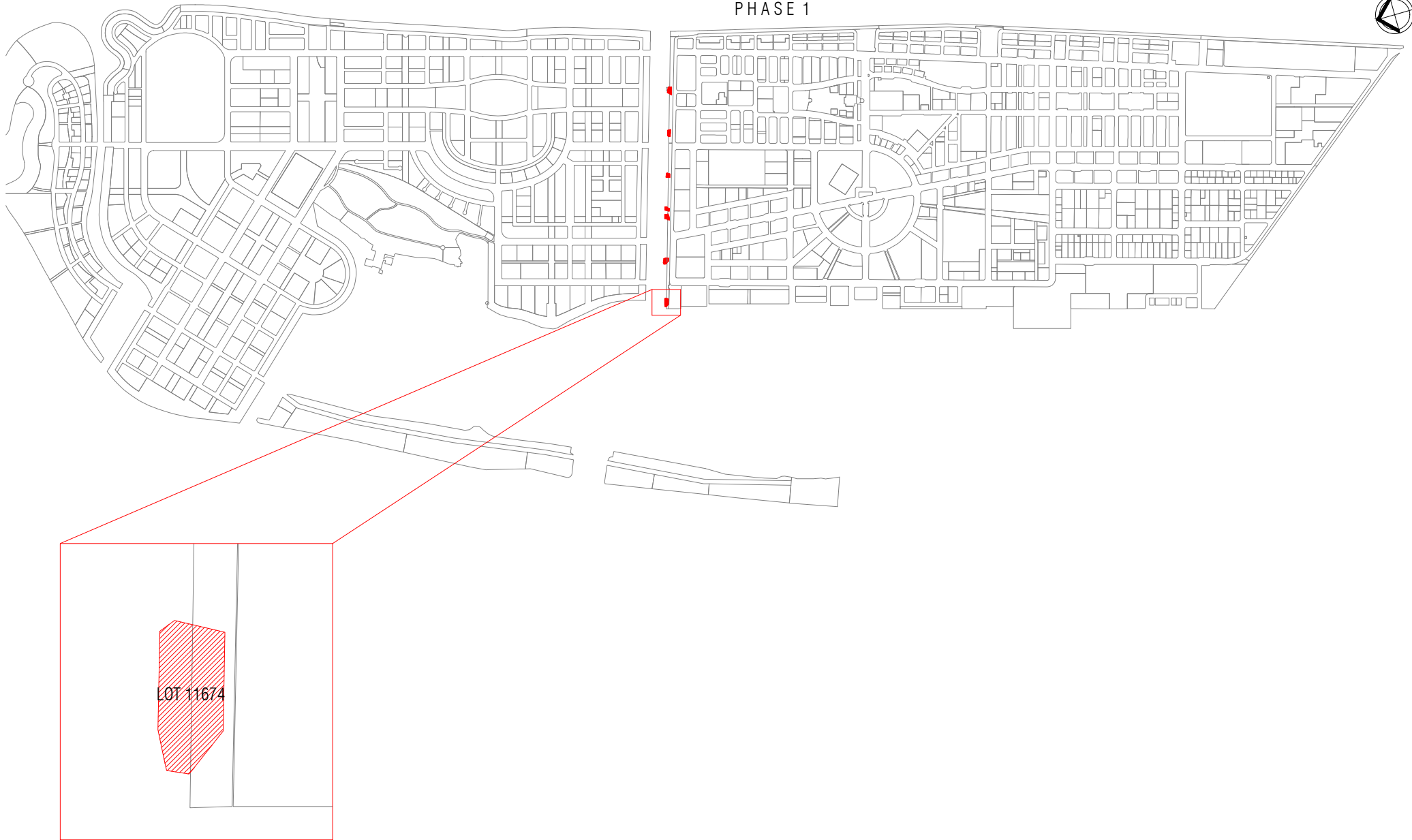

PROJECT: LOT 11674 - Channel Park Cafe 1 (Phase 1)

Scale: N.T.S

Drawn by: Shadheen

Checked by:

Date: 3rd August 2021

Remarks:

DRAWING: LOCATION MAP



PLANNING AND DEVELOPMENT DEPARTMENT  
3RD FLOOR, HDC BUILDING HULHUMALE'  
REPUBLIC OF MALDIVES  
TEL. +(960)3353535, FAX +(960)3358892  
EMAIL : planning@hdc.com.mv



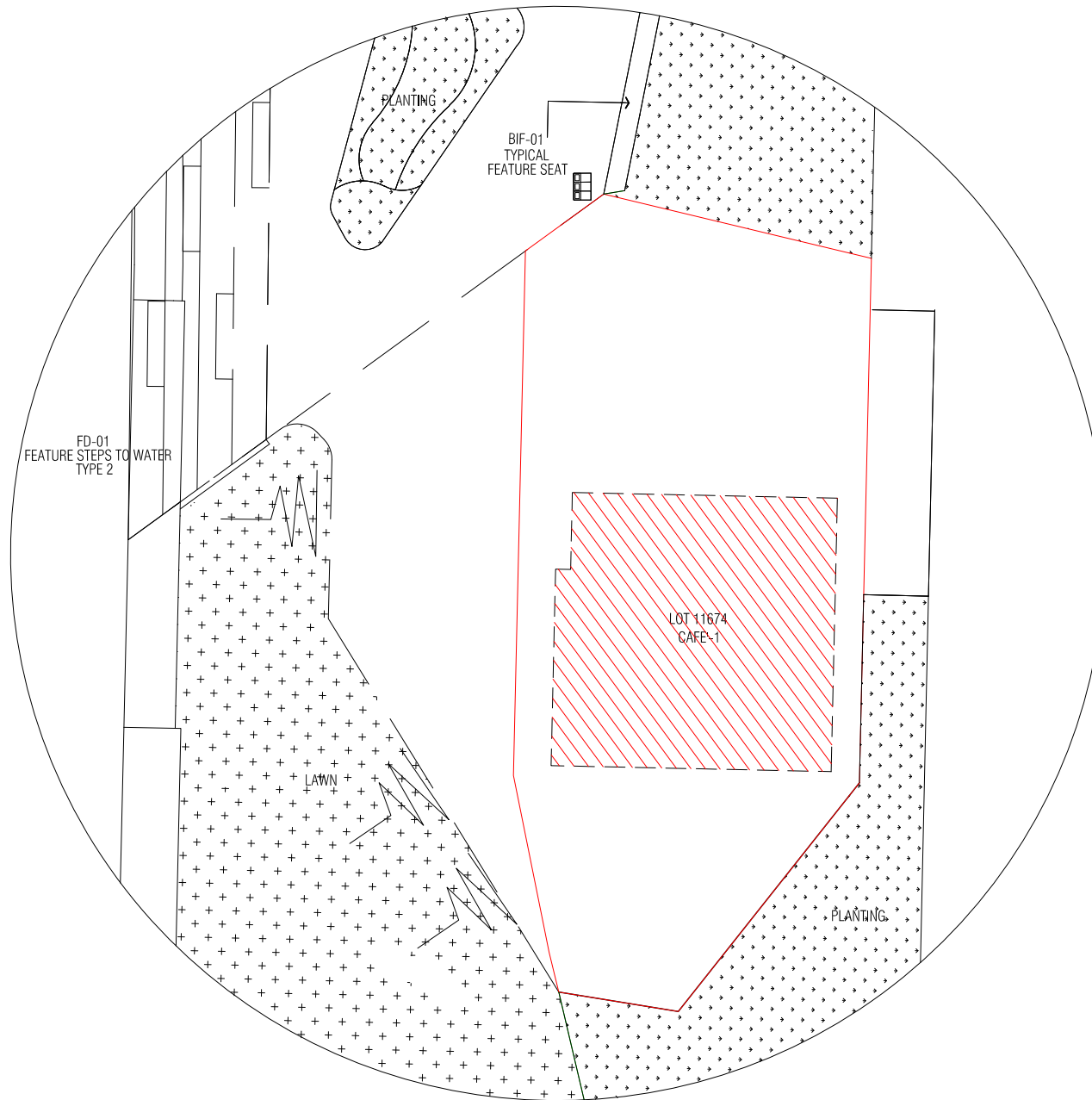

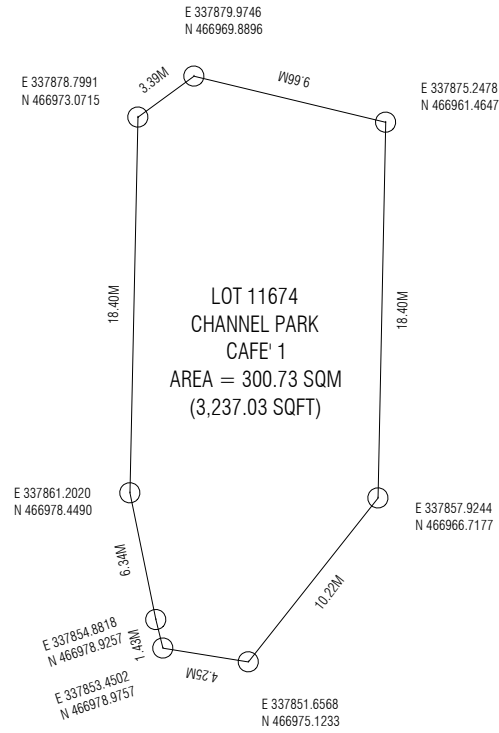

PROJECT: LOT 11674 - Channel Park Cafe 1 (Phase 1)

Scale: N.T.S

Drawn by: Dhimyan

Checked by: *DL* Date: 3rd August 2021

Remarks:

DRAWING: PLOT MAP

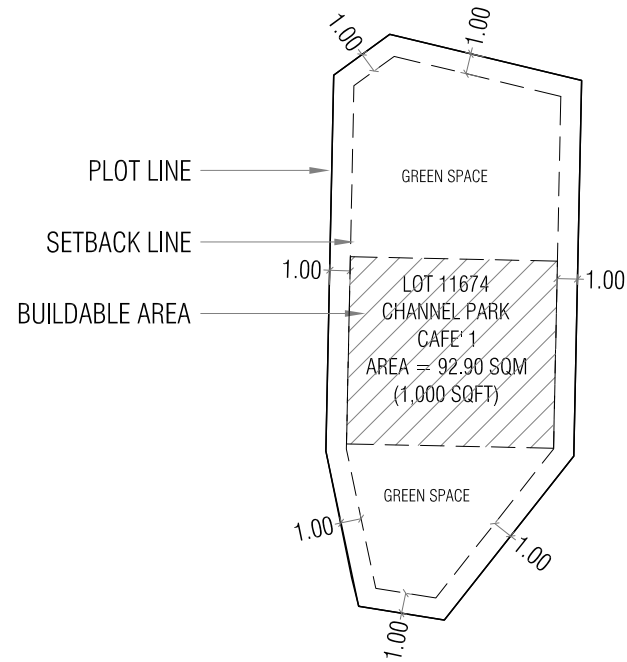

## 2. DESIGN AND DEVELOPMENT GUIDELINE

(Refer to Next Page)

**HULHUMALE PLANNING & DEVELOPMENT GUIDELINE:**  
**CHANNEL PARK : COMMERCIAL F&B**

**1. INTRODUCTION**

- 1.1 This guideline will be applicable to the commercial & developments at commercial F&B of hulhumale' phase 1 & 2 of Channel Park (please refer to the development drawings).
- 1.2 Concept Level drawings (site plan showing the surrounding context, floor plans, conceptual sections and elevations), and spatial layout, showing the overall classifications and requirements of the development must be submitted to HDC for comments before proceeding to final architectural and structural drawings.
- 1.3 A master-plan stating the phases of the whole development should be submitted to HDC, if applicable.
- 1.4 Final detail drawing approval and related construction approvals need to be obtained from HDC, before the construction of any building in Hulhumale'.
- 1.5 Final detail drawing set should be signed and stamped by a registered local architect/structural engineer.
- 1.6 Under these guidelines, a building is defined to be a constructed dwelling that is not movable/portable within a given plot and one that is finished using different materials and is constructed to a certain standard that is acceptable to HDC.

## **2. USAGE OF LAND**

- 2.1 These allocated land plot is to be used for commercial F&B (Food and Beverages) activities such as, restaurants/café's and coffee shops, etc.
- 2.2 Fire and safety system approved by the Ministry of Defense and National Security should be established within the building.
- 2.3 Following are prohibited uses for these single storey developments:
- 2.3.1. Any type of commercial spaces such as shops, convenient stores, and markets, etc.
  - 2.3.2 Large scale industrial use, any use where public is disturbed from loud noises, smell or dust generating and carrying activities, constructing go downs.

## **3. BUILDING HEIGHT, F.S.I AND SETBACK PLAN**

- 3.1 Single floor buildings are allowed with a height of 3.2 from pavement to roof beam level. A maximum height of 1.2 meters are allowed for roof pitch, resulting in a total building height of 4.4 meters for the development.
- 3.2 Minimum height between finished floor levels to slab/ceiling soffit level is 2.7 meters.
- 3.3 A minimum width of 1 meter setback is to be provided within the development.
- 3.3 No part of the building such as roof eave, gutters and door/window panels etc. should be projected out into the road or beyond 1 meter from the given building line.

## **4. BOUNDARY REQUIREMENTS**

- 4.1 Urban landscape interaction is highly encouraged at Channel Park areas, hence it is advised to avoid any boundary walls such as parapet solid (masonry) walls.
- 4.2 If required the developer may choose to create boundaries with perforation or demarcate the plot boundary with a natural green verge, planter boxes, or picket fence that is 600mm height from finished floor level.

## **5. ACCESS AND CIRCULATION**

### **5.1 PEDESTRIAN**

- 5.1.1 A safe accessibility provision with ease of circulation should be provided as much as possible to all type of users particularly the elderly and physically impaired.

## **6. DEPTH OF FOUNDATION**

6.2 Depth of foundation for each building would be determined by the structural engineer of the building.

## **7. GENERAL REQUIREMENTS**

Intention : Recommendations stated below are to help support the sustainable development of commercial F&B areas at the Channel Park - Phase 1 & 2 of Hulhumale'.

7.1 The development may accommodate a bicycle parking space if necessary, and should provide a service area with ease of accessibility for the service providers.

7.2 A Garbage collection area should be provided within the footprint of the Café' plot. And it should not be less than 1.5% of the total footprint area.

7.3 As a dedicated area for service providers, a waste disposal mechanism with ease of loading should be established;-

7.3.1 This waste disposable space should be fenced and cannot be a fully enclosed wall. And the height should not be less than 2m from finished floor level.

7.3.2 Allocated area for this space should not be less than 1.5% of total plot area.

7.3. Atleast one access to the development zones, or both if inclusive should be designed to cater for the ease of emergency evacuation as well.

7.4. Atleast one toilet should be provided within the footprint of the development, and it should fit the requirements of a disability access toilet.

7.5. Mechanical and Electrical provisions should be given to allow easy connections of air conditioning, etc. within the development.

7.6. All cafés and restaurants in the development, should adhere to all requirements set forth by the Food & Drug Authority relating to food storage/preparation/service & disposal.

7.7 For the levels differences at the channel park zones, steps, access ramps, and stepping stones can be created as egress and ingress.

7.8 For outdoor area of the Café' development, shading devices such as parasols may be allowed.

**NOTE: In addition to this, please refer to the accompanying guideline drawings**

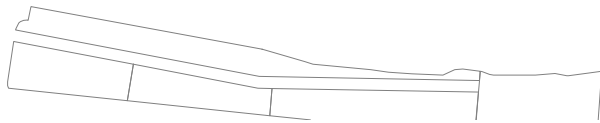
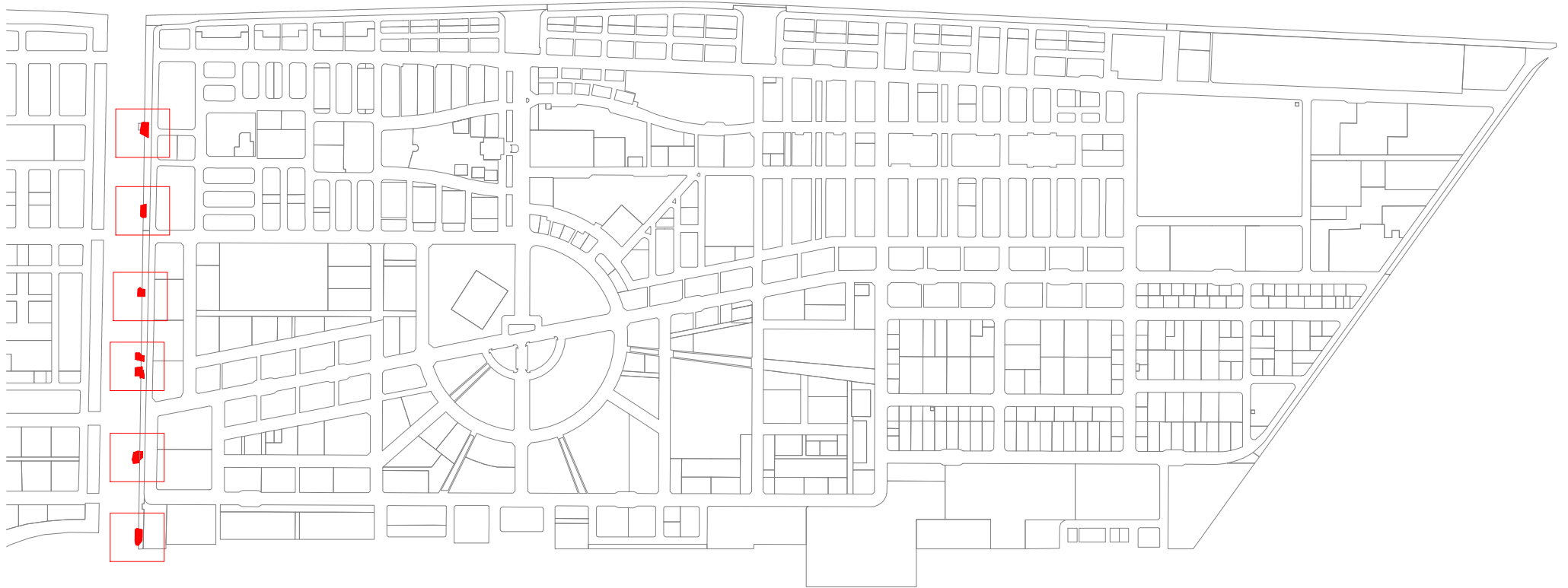



PHASE 1

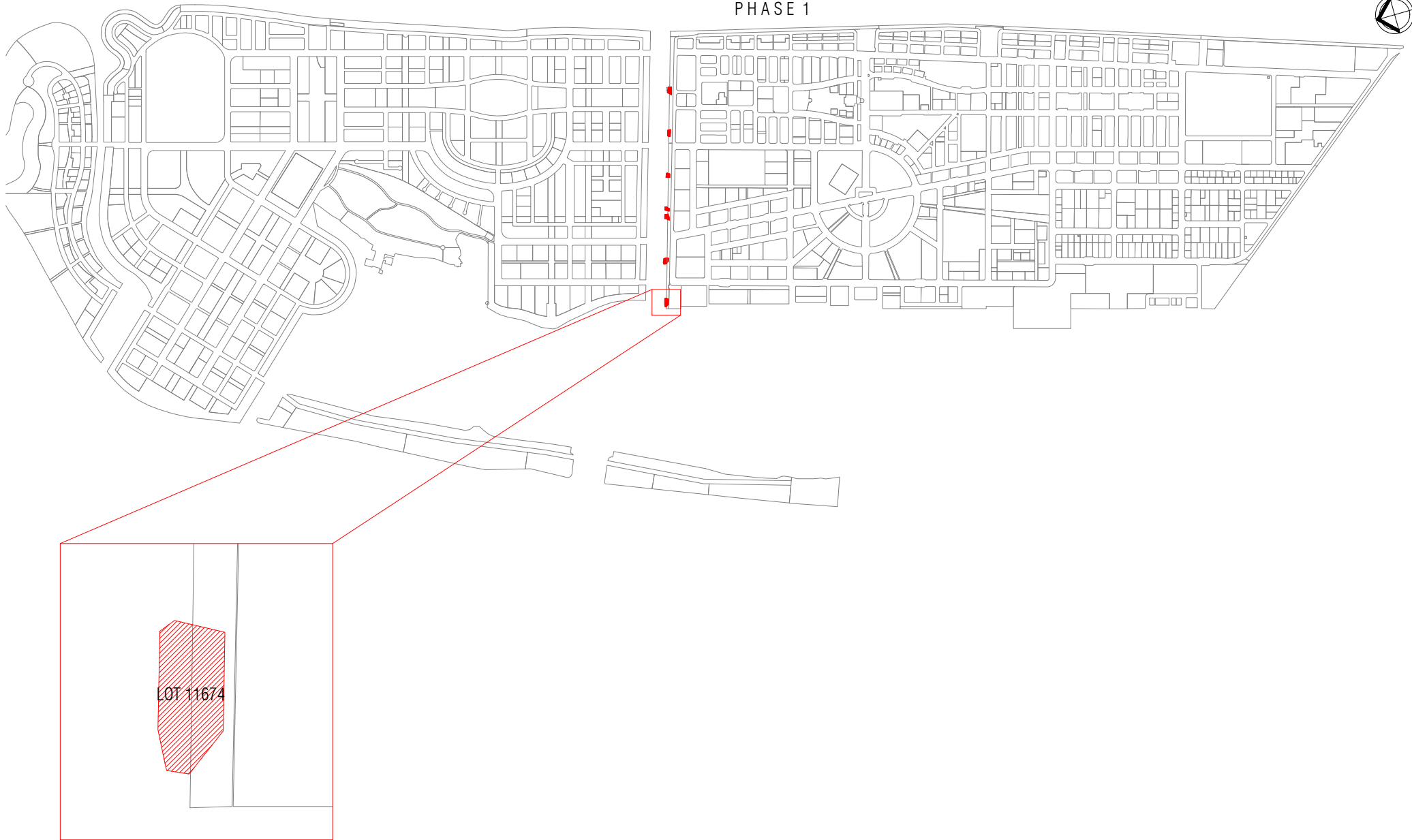

PROJECT: LOT 11674 - Channel Park Cafe 1 (Phase 1)

Scale: N.T.S

Drawn by: Shadheen

Checked by:

Date: 3rd August 2021

Remarks:

DRAWING: LOCATION MAP



PLANNING AND DEVELOPMENT DEPARTMENT  
3RD FLOOR, HDC BUILDING HULHUMALE'  
REPUBLIC OF MALDIVES  
TEL. +(960)3353535, FAX +(960)3358892  
EMAIL : planning@hdc.com.mv

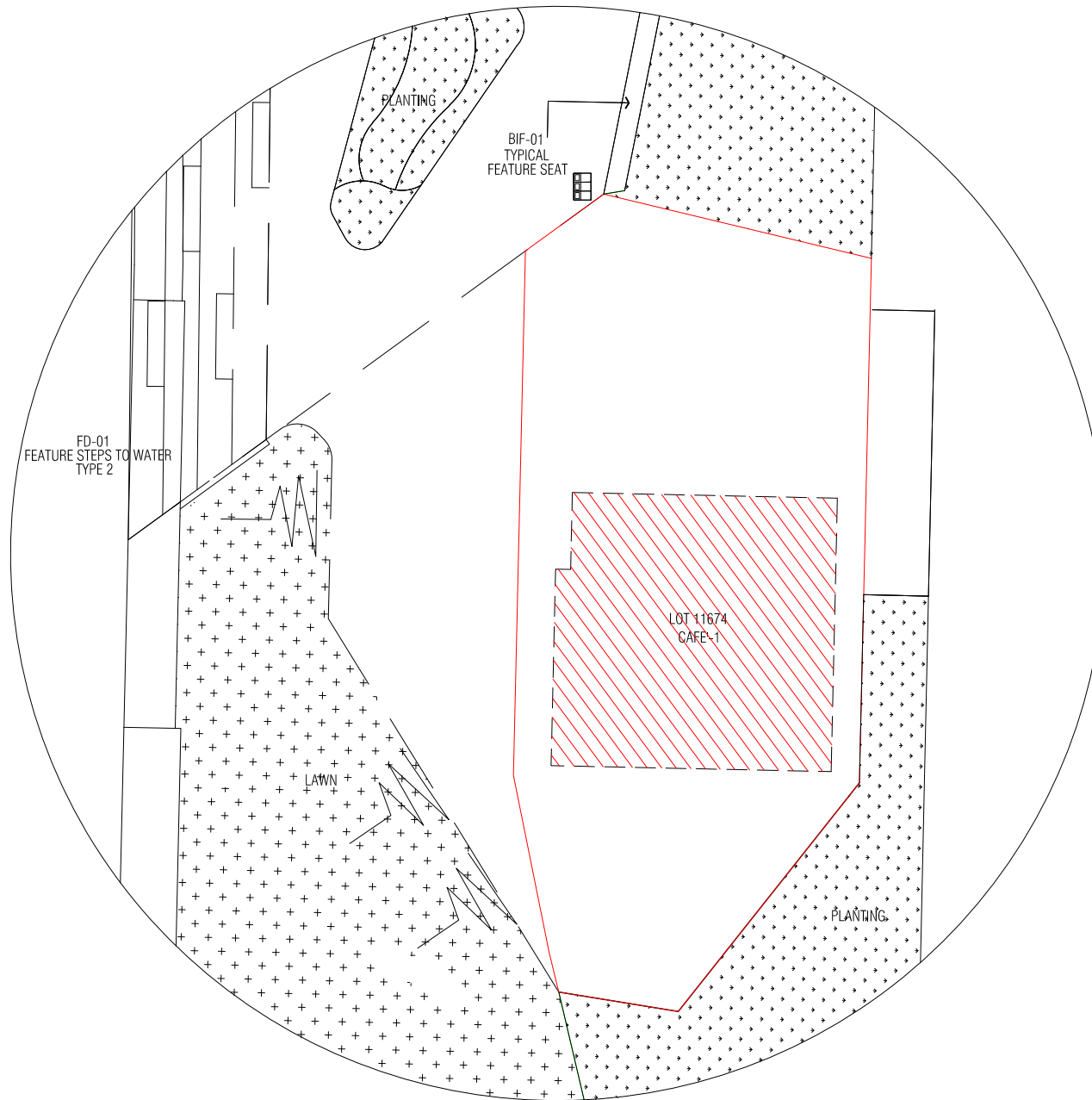

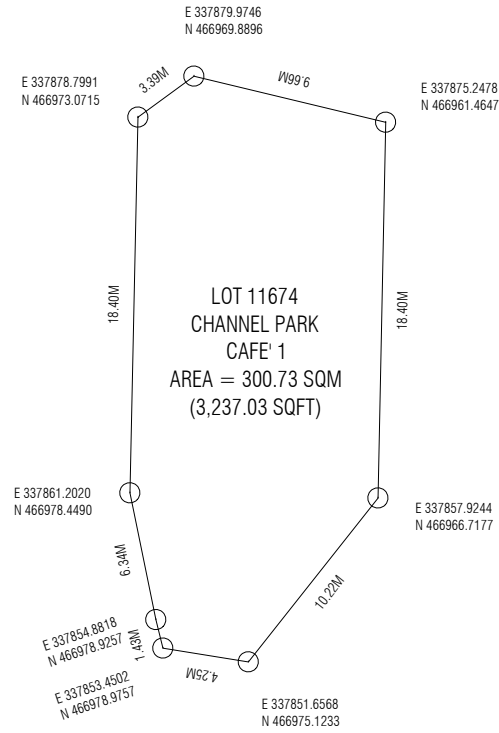

PROJECT: LOT 11674 - Channel Park Cafe 1 (Phase 1)

Scale: N.T.S

Drawn by: Dhimyan

Checked by: *DL* Date: 3rd August 2021

Remarks:

DRAWING: PLOT MAP

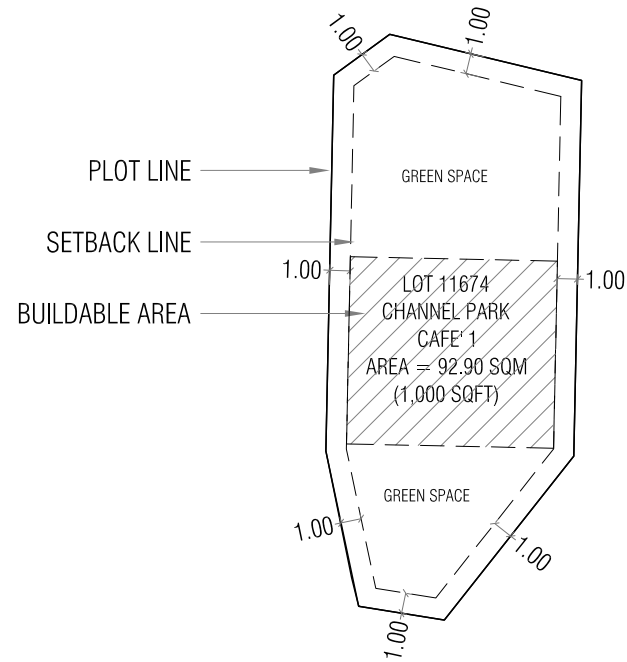

### 3. SUBMISSION & QUALITY MANAGEMENT CRITERIA

(Refer to Next Page)





PLANNING & DEVELOPMENT DEPARTMENT

# **SUBMISSION & QUALITY MANAGEMENT CRITERIA**

## 1.0 SUBMISSION (DELIVERABLES AND CRITERIA)

### 1.1 CONCEPT DESIGN STAGE

Concept drawings should focus on how it is integrated to site and surrounding context. All floor plans should indicate the usage of specific floor spaces with its area as well as built Up Area (BUA) along with gross floor area (GFA).

Format of submission should include (but is not limited to) a PowerPoint presentation of the concept design stage submission. A compiled PDF of the above documents should be submitted in digital format. AutoCAD drawings should be submitted for all the drawings.

Concept design should include the following drawings & documents (minimum requirement);

#### A. ARCHITECTURAL

1. Concept brief
2. Location plan
3. Site plan showing the surrounding context
4. Parking layouts
5. Vehicular and pedestrian circulation layout addressing the surrounding context
6. Floor plans, sections and elevations
7. Relevant blow-up details
8. Proposed material schedule and mood board
9. Interior and exterior perspective images (3D rendered visuals)

#### B. STRUCTURAL

Structural concept will include the following drawings and documents;

1. Layout plan drawing showing the structural members (such as column, beam, slabs, sheer wall. etc.) with estimated size & location. Details regarding selection of member size without effecting architectural concepts. (Details of clear heights achieved in specific locations can be highlighted)
2. A report stating:
  - a) Pro and cons of the preferred structural system with respect to the architectural design.
  - b) Explain the structural system in relation to structure's durability for the intended lifetime of the building.
  - c) Explain the Structural design including the design code, design parameters (considered loads) & analysis method preferred by structural design engineer, details of the software(s) to be used for design, formats of design sheets (if any).
  - d) Details of proposed foundation system based on the available geotechnical parameters. It should be noted that the wind speed for the design can be obtained from local metrological department.
  - e) Assessment of the environmental conditions and the requirement that is applicable for the design with reference to code of practices. This includes, but not limited to covers to be provided for reinforcement, grade of steel, water proofing for foundation, min concrete grade with maximum water cement ratio, admixtures to be used for concrete etc. based on standards.
  - f) Minimum cement content details for different grades of concrete, in order to achieve a durable concrete for its intended life time
  - g) Details regarding fire rating of the building

#### C. BUILDING SERVICES

Proposals for the following systems must be submitted as a report

1. Air-Conditioning System and proposed locations
2. Mechanical Ventilation System and proposed locations
3. Fire Safety Design
  - a) Fire Detection and Alarm System

#### SUBMISSION & QUALITY MANAGEMENT CRITERIA

---

- b) Portable extinguisher
- c) Fire blankets
- d) Dry riser system
- e) Hose reel system
- f) Wet Riser System
- 4. Water, Drainage and plumbing proposal
- 5. Vertical Transportation Services (Lift)
- 6. Lighting and Power System
- 7. Emergency Lighting System
- 8. Earthing System
- 9. Lightning Protection System
- 10. Emergency Electrical Supply (Generator Set)
- 11. GPON in building network
- 12. Building Access Control
- 13. CCTV System
- 14. Public Address System
- 15. Carpark Barrier Gate System

## **1.2 DETAILED DESIGN STAGE**

Detailed design will be submitted after concept design approval as follows:

1. Architectural drawings (by a locally registered professional architect) of all plans, elevations and major sections. (Refer to local planning guidelines)
2. Structural drawings and calculations, methodology (stamped and signed by a locally registered professional engineer)
3. Foundation protection method
4. Building services drawings (electrical, water plumbing and sewage, GPON, HVAC, Vertical transport, Fire Safety)
5. Material and finishing schedule
6. Local authority approvals, including but not limited to Fire Drawings and Panel board drawings.
7. Soil Investigation/Geotechnical Survey report (If required)
8. Environmental Impact Assessment report

Minimum three (3) sets of the above-mentioned drawings and documents should be submitted. Drawings Submission Form with the appropriate parts filled and signed by Registered Architect and Engineer.

## **1.3 SHOP DRAWINGS AND AS BUILT**

The following drawings shall be submitted after completion of construction and prior to usage of the building.

- As built Architectural drawings
- As built Structural drawings
- As built Services drawings (Water, Sewage, Electrical, Ventilation & Air-conditioning, Firefighting and Communication/GPON)
- Copy of approvals given by Authorities, such as but not limited to MNDF Fire, Ministry of Health, STELCO, MEA, MWSC

With the submission of required documents, HDC would provide the necessary feedback for each stage. In giving feedbacks we would check whether it fits the development guidelines, design guidance documents, international standards and the standards set by HDC. A two-way dialogue to attain a satisfactory level of work will be pursued. Upon submission of the documents HDC reserves a duration of 14 working days to process and provide comments or approval. A period of 14 working days will be taken to provide comments for concept drawing. If the drawings are not approved and comments are sent after checking, revised drawings are to be submitted within 14 working days. Please note that for each submission 14 working days will be taken to comment. In addition to that, the duration taken to comment on Detail drawings stage will be minimum of 10 working days and maximum is 20 working days



If the party fails to correct after sending comments twice, the party needs to apply again as a new project proposal along with the application fee. This is to encourage carefulness from the client and to maximize efficiency from both stakeholders.

Once the concept drawings are approved, the detail drawings shall comply to the approved concept drawings and if in any case if there are changes to such as floor plans sections and elevations in the detail stage, a revised concept drawings approval should be submitted. It is mandatory to approve concept if the changes need to be brought to aforementioned drawings.

Physical implementation process can be initiated once drawing approval is given by HDC. Any modifications or amendments to the drawings should be informed and applied for approval prior to initiating any physical works on site which contradicts the approved drawings. Drawings and documents mentioned in shop drawings and as-built drawings can be submitted during implementation or after construction prior to applying for building usage permit. With the Successful completion and submission of the documents and drawings and after fulfilling of other mandatory requirements set by the Building Control Unit, Building Usage Permit will be awarded.

## 2.0 REQUIREMENTS OF THE CONSULTANT

Developer is required to hire a locally registered Project Management (PM) consultant for the quality assurance of the building. The PM consultant should be a 3<sup>rd</sup> party independent person or a firm that is locally registered under Ministry of National Planning, Housing & Infrastructure. This consultant should be unbiased in the works and while reporting to HDC. The consultant should be hired prior to the commencement of any site works. Once hired, the consultant should approve and submit a Construction Quality Management Plan (CQMP) from the Developer or Contractor before any physical works on site are carried. Duties and responsibilities of the consultant are as follows:

### 2.1 RESPONSIBILITIES

#### A. ASSURANCE OF CONSTRUCTION QUALITY

Necessary tests should be carried out on site and off site to ensure the quality of the final product. This includes, but not limited to compressive strength of concrete, tests done to ensure strength of steel, Slump test, Sieve Analysis and material specifications.

#### B. ASSURANCE OF FINISHING QUALITY

Consultant should ensure that the works are carried out according to the approved standards, methodologies, CQMP and drawings and if not mentioned as per the best practices followed. Consultant should also ensure that all works are carried out using approved materials which meets the standards as per the guidelines and the intended purpose for quality, safety and durability.

#### C. MATERIAL APPROVAL

All the materials used in the building structure, services and finishing shall be approved by the consultant. In approving the materials, the consultant shall ensure it meets the standards as per the guidelines and the intended purpose for quality, safety and durability. All the records of approved materials and its specifications should be kept and shared to HDC according to the reporting criteria.

#### D. APPROVE METHODOLOGIES

Prior to commencement of any construction works, Consultant should evaluate, suggest any improvements and approve method statements submitted by the developer. Consultant should ensure that the approved methodologies meet the intended purpose. All the methodology approvals should be kept on record and shared with HDC according to the reporting criteria.

#### E. ISSUING SITE INSTRUCTIONS

Issued site instructions should be recorded and submitted to HDC as per the reporting criteria.

#### F. APPROVE AS-BUILT DRAWINGS

The consultant should ensure the approved as-built drawings are accurate and meets onsite physical development.

## 2.2 REPORTING

All the following reports should be signed or stamped by the consultant. All the monthly reports should be submitted by the consultant before 10<sup>th</sup> of every month.

### A. INITIAL REPORT

- i. Construction Quality Management Plan (CQMP)
- ii. Safety Plan
- iii. Work methodologies

### B. MONTHLY REPORT

- i. Project Brief
- ii. Ongoing works and upcoming works for the next month
- iii. Overall construction progress showing the planned vs actual progress in the form of a Gantt chart
- iv. Accidents report
- v. Challenges faced during implementation
- vi. Test & Analysis reports
- vii. List of attended inspections and its reports
- viii. List of instructions given on site
- ix. Documentation of approved methodologies
- x. Documentation of approved materials

### C. PROJECT COMPLETION REPORT

- i. Summary of Project
- ii. Challenges faced during the implementation
- iii. Maintenance requirements
- iv. Services systems manuals
- v. As-Built Drawings